

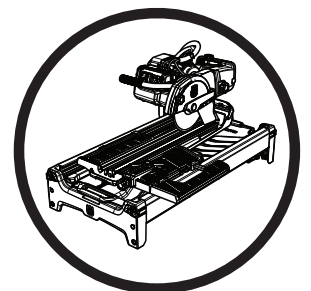

**Workshop manual**  
**TS70/TS90**



# LEGEND

Clicking the title will bring you to the beginning of that chapter.

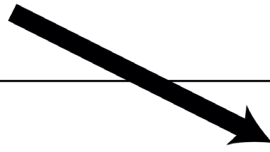

**11**

## REPAIR INSTRUCTIONS

**1**

**2**

**3**

**4**

**5**

**6**

**Replace the lower belt.**

First see **Remove motor and grinding head from frame (p. 19)**, **Remove motor from grinding head (p. 19)**, **Remove upper belt (p. 20)**, **Open grinding head (p. 21)**

1. Pull the belt upwards in parallel with turning the wheels by hand.
2. Remove the belt.
3. Thread the belt according to picture.
4. Use the Installation Tool to mount the belt.
5. Turn the lever and press the belt downwards.
6. Continue to roll on the belt until it is below the rim on all wheels. Varningssymbol/text. The yellow side of the belt should be faced in

**i Information!**  
Also replace bearings and sealings while replacing the lower belt.

**1**

**2**

**3**

**Remove satellites**

1. Turn the grinding house upside down and put it on two pieces of 2x4 boards. Then unscrew the centre bolt of the satellite.
2. Lift off the satellite.
3. Make sure to recover the three pegs.

Reverse steps for assembly

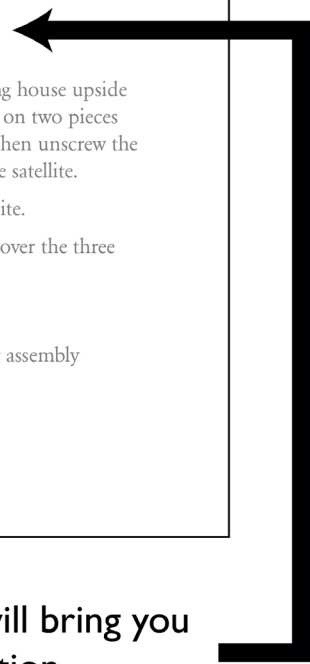

Alt + Left arrow = Back  
Ctrl + L = Fullscreen

Clicking a black circle will bring you to the Tools section.

**3. Literature**

Workshop Manual ..... 5  
 Spare Parts Catalogue ..... 5  
 Operator’s Manual..... 5

**4. Safety Instructions**

General ..... 6  
 Warning and Information ..... 6  
 ESD general notice ..... 6

**5. Tools and Special Tools**

Tools ..... 7

**6. Components - Navigation**

TS70/TS90 Navigation..... 8  
 Electrical Cabinet Navigation ..... 9

**7. Troubleshooting**

Function test: ..... 10  
 Before starting to troubleshoot, make sure that: ..... 10  
 Troubleshooting guide ..... 11

**8. Repair Instructions**

Remove the conveyor cart steel rods..... 12  
 Mount the conveyor cart steel rod..... 12  
 Remove the blade guard and belt cover..... 13  
 Remove the Belt..... 13  
 Remove the Blade Shaft ..... 14  
 Replace Blade Shaft Bearings ..... 15  
 Replace the Pulleys..... 15  
 Motor replacement..... 16  
 Mount the Belt..... 17  
 Removing the Conveyor Cart/Support Arm Cable (Only TS90)..... 18  
 Mount the Cart/Support Arm Cable (Only TS90) ..... 20  
 Click for 3D steps..... 20  
 Replace the Support Arm Wheels and Bearings (Only TS90)..... 22  
 Measure/Adjust the Conveyor Cart Wheel Traction..... 23  
 TS70 - Setting the blade parallel and in center of the cutting slot. .... 24  
 TS90 - Setting the blade parallel and in center of to the cutting slot ..... 26  
 Setting the Blade angles to the conveyor cart surface. .... 28  
 Setting the depth stop for the blade..... 30  
 Capacitor Check..... 31  
 Motor winding inductance measuring, single voltage ..... 32  
 Motor winding inductance measuring, dual voltage..... 34

**9. Specification**

Motor measuring values - Single voltage..... 35  
Motor measuring values - Dual voltage ..... 35

**10. Wiring Diagram**

Single Voltage..... 36  
Dual Voltage ..... 37  
Dual Voltage Motor Windings..... 38

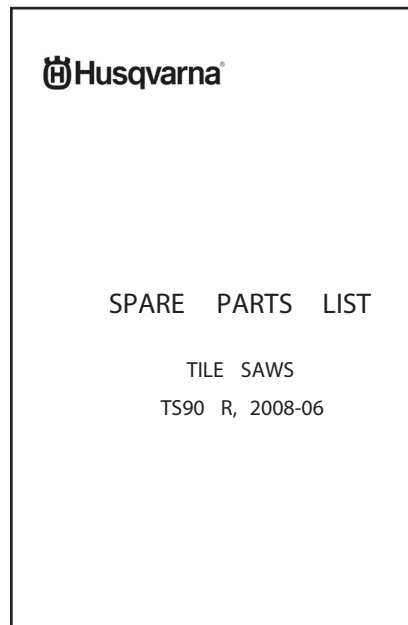

### 3. LITERATURE

#### Workshop Manual

The workshop manual covers all workshop maintenance for the TS70/TS90. Some very simple and obvious repair work has been omitted.

The manual is divided into numbered chapters as well as chapter headings that are specified in bold at the top of each page.

The table of contents at the beginning of the manual also has a page reference to the beginning of each chapter.

#### Spare Parts Catalogue

These catalogues include all the spares for Husqvarna TS70/TS90.

The catalogues contains exploded views for each product. Location, spare part number can be identified.

#### Operator's Manual

The Operator's Manual describes how to operate and handle the product safely. It also contains a guide for maintenance that should be carried out by the operator.

Documentation:  
<http://support.husqvarnacp.com>

## 4. SAFETY INSTRUCTIONS

### General

The operator and the service technician should have read and understood the content of the Operator's Manual before operating or servicing the product.

- No one may repair the TS70/TS90 unless they have read and understood the contents of this workshop manual.
- This workshop manual is written for personnel with general knowledge about the repair and service of TS70/TS90.
- The workshop where the TS70/TS90 is to be repaired must be equipped with safety equipment in accordance with local bylaws.
- The machine is tested and approved only with equipment originally provided or recommended by the manufacturer.
- It is the responsibility of the user of this workshop manual to ensure that the service and repairs are carried out according to legal requirements to protect the health and safety of the personnel undertaking the work.
- Always read the warning label on the packaging for Loctite and oil, and act according to its instructions.
- Always stop the TS70/TS90 before carrying out any service or repairs.
- When using compressed air, do not direct the jet towards the body. Air can penetrate into the blood circulation system, which could be fatal.
- Observe local waste regulations.
- Electric shock could cause injury. Do not touch the wires while the TS70/TS90 is on or plugged in.
- Always make sure all nuts and bolts are correctly tightened.
- Wear personal protective equipment.
- Never carry the machine by holding the cable and never pull the plug by pulling the cable.
- Check that the cables are intact and in good condition. Use cables intended for outdoor use.
- Never use the machine if any cable is damaged.

### Warning and Information



---

The warning box indicates there is a risk of personal injury if the instructions are not followed.

---



---

The information box provides instructions for the reader.

---











### ESD general notice

All electrical devices are sensitive to Electrostatic Discharges (ESD). A person may carry thousands of volts from being charged sitting in a car seat, wearing shoes with synthetic soles or a synthetic jacket. All discharges one can feel is certain to destroy electronic components. Even those discharges one can't feel may still damage or destroy electronic components. When working with electronic components in our products, always use proper ESD protection!.

**5. TOOLS AND SPECIAL TOOLS**

In the list below all tools and the special tools used in this workshop manual is found.

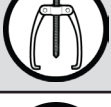
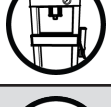
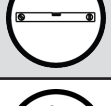
**Tools**

<b>Tool</b>	<b>Tool no.</b>	<b>Description</b>
	531 11 95-32	Ratchet Wrench
	531 11 95-33	Wrench
	525 45 52-01	Allen Key, Kit 2.5 - 10 mm
		Socket
		Deep socket
		Screwdriver
		Steel Ruler, 0 - 300 mm
		Set Square
	504 90 90-02	Outer Bearing Puller
		Workshop press
		Spirit-level
		Multimeter (With possibility to measure capacitance and inductance)

## 6. COMPONENTS - NAVIGATION

## TS70/TS90 Navigation

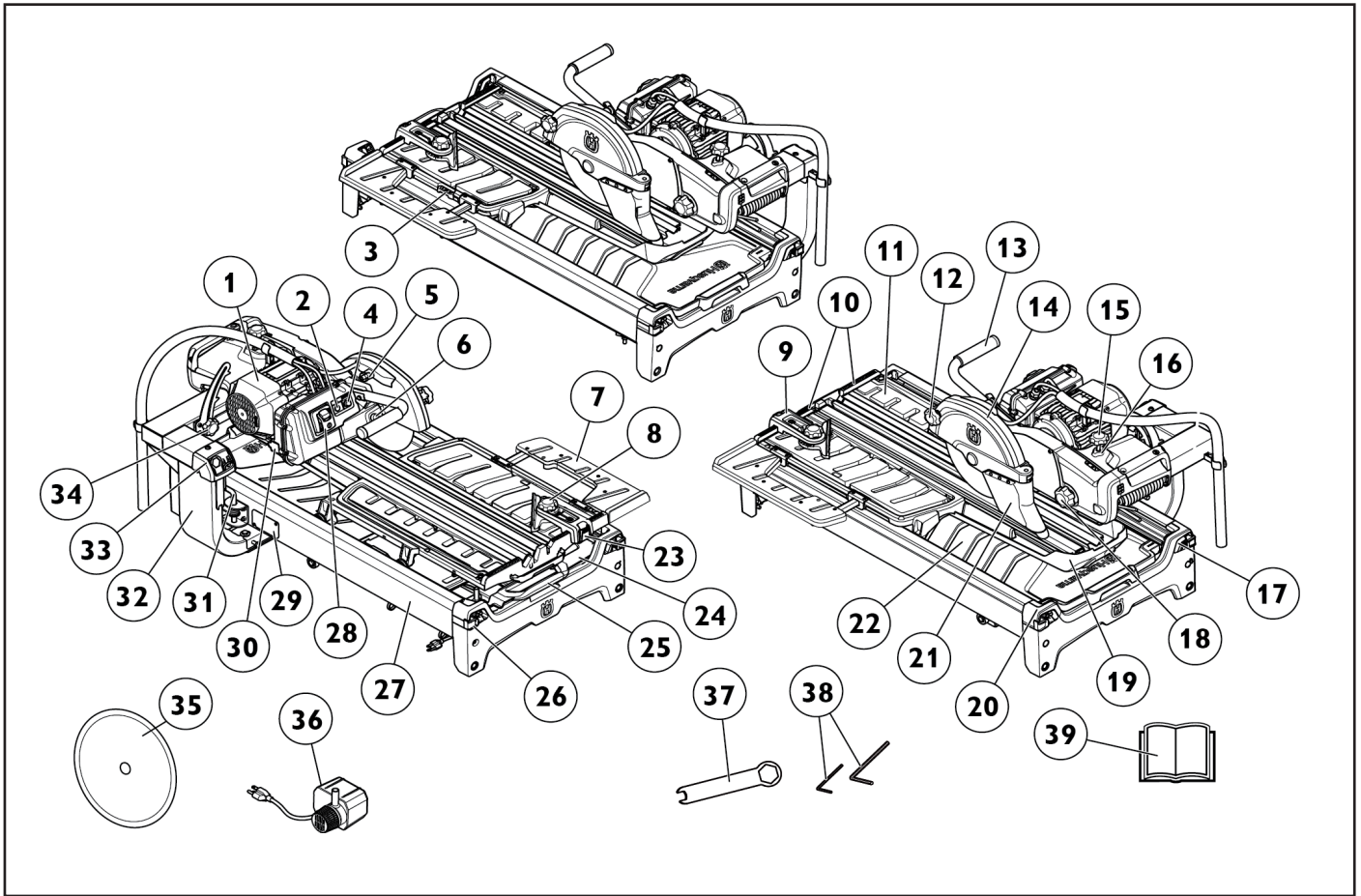

- |   |  |   |
|---|--|---|
| 1. Electric motor                               | 15. Knob, depth stop adjustment        | 28. Power switch                                  |
| 2. Overload lamp                                | 16. Locking nut, depth stop adjustment | 29. Service hatch, wire system (TS90)             |
| 3. Locking knob conveyor cart (TS70)            | 17. Lifting eye, 4 pcs                 | 30. Dual voltage switch (TS90 dual voltage)       |
| 4. Overload protection                          | 18. Locking knob, depth adjustment     | 31. Locking knob, support arm (TS90)              |
| 5. Valve, water to blade ON/OFF                 | 19. Slurry collector tray, front       | 32. Support arm                                   |
| 6. Button, locking blade shaft                  | 20. Stop, conveyor cart                | 33. Tool holder                                   |
| 7. Side table                                   | 21. Splash guard                       | 34. Locking knob, miter cutting                   |
| 8. Locking knob, angle adjustment cutting guide | 22. Water collector tray               | 35. Blade -Husqvarna GS2 varicut S (Ø250 mm, 10") |
| 9. Cutting guide                                | 23. Snap connection, cutting guide     | 36. Water pump                                    |
| 10. Ruler                                       | 24. Water container                    | 37. Spanner                                       |
| 11. Conveyor cart                               | 25. Slurry collector tray, back        | 38. Allen key                                     |
| 12. Locking knob, blade guard                   | 26. Extensible handles, 4 pcs          | 39. Operator's Manual                             |
| 13. Handle, cutting arm                         | 27. Frame                              |   |
| 14. Blade guard                                 |  |   |

## Electrical Cabinet Navigation

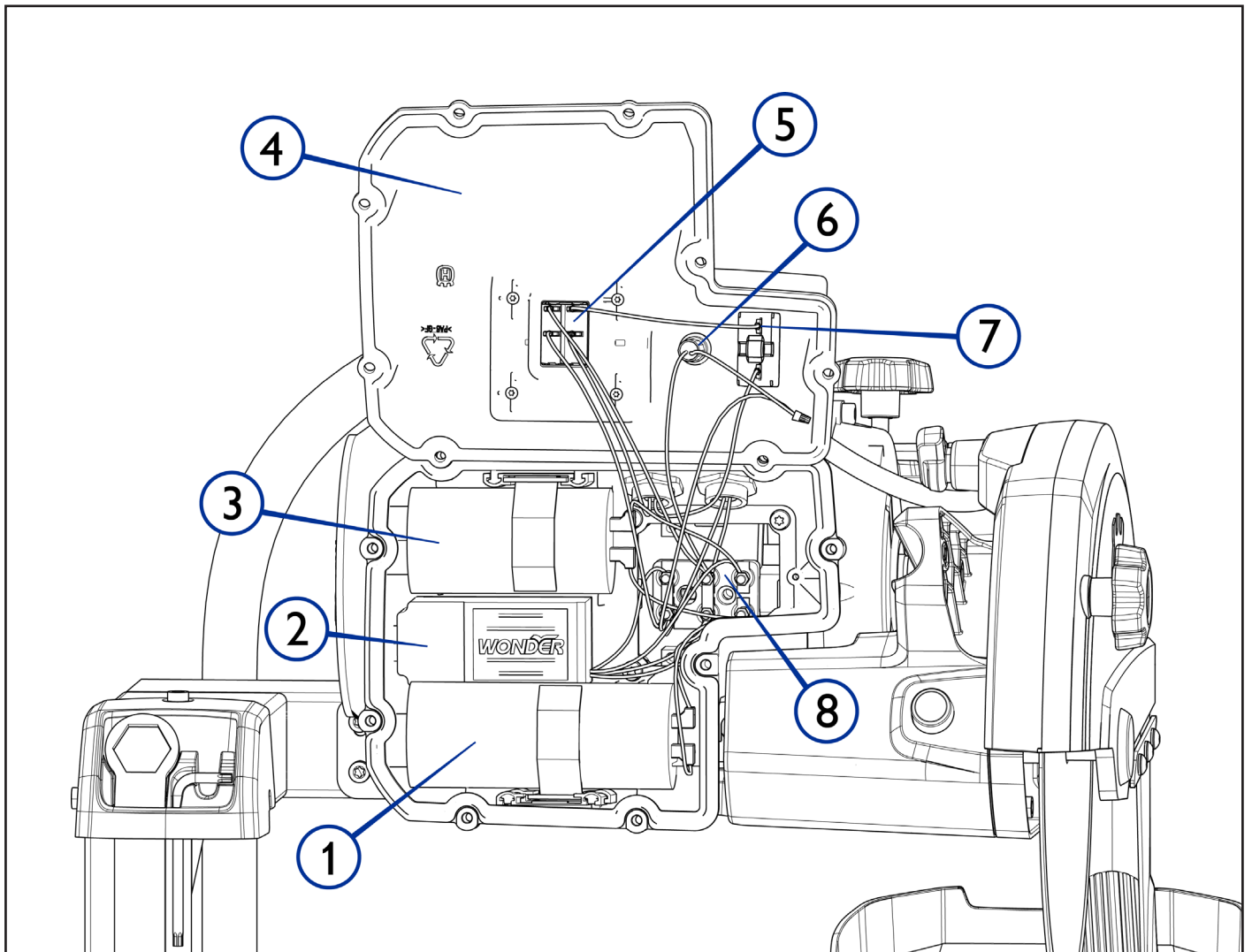

- |                              |   |
|------------------------------|---|
| 1. Running capacitor         | 5. Power switch   |
| 2. Electronic starter switch | 6. Overload lamp  |
| 3. Starting capacitor        | 7. Overload protection  |
| 4. Electric cabinet          | 8. Connection block (single voltage)<br>/ Screw terminal (dual voltage) |

## 7. TROUBLESHOOTING

### Function test:

- Move the conveyor cart back and forward to make sure it can move freely without friction and noise.
- Rotate the blade by hand to make sure it is not wobbling and that it can rotate without friction and noise.
- Examine the blade to make sure it is not damaged or worn out.
- Inspect the external cable, plug and connectors.
- Connect the saw to a power source with the correct voltage and fusing.
- Start the motor with the ON/OFF switch. The motor should then reach its operating speed within approximately 2 seconds.
- Examine the saw for unexpected noise and vibrations while the motor is running.
- Make sure the motor stops when the power switch is set to OFF.

### Before starting to troubleshoot, make sure that:

- The product is disconnected from the power source and that the motor switch is in its OFF position.
- The blade can rotate freely.
- The fuse, voltage and frequency in the power source is according to the product specifications. See the Operator's manual.
- The extension cables are in good condition, not too long or having a too small gauge.

## Troubleshooting guide

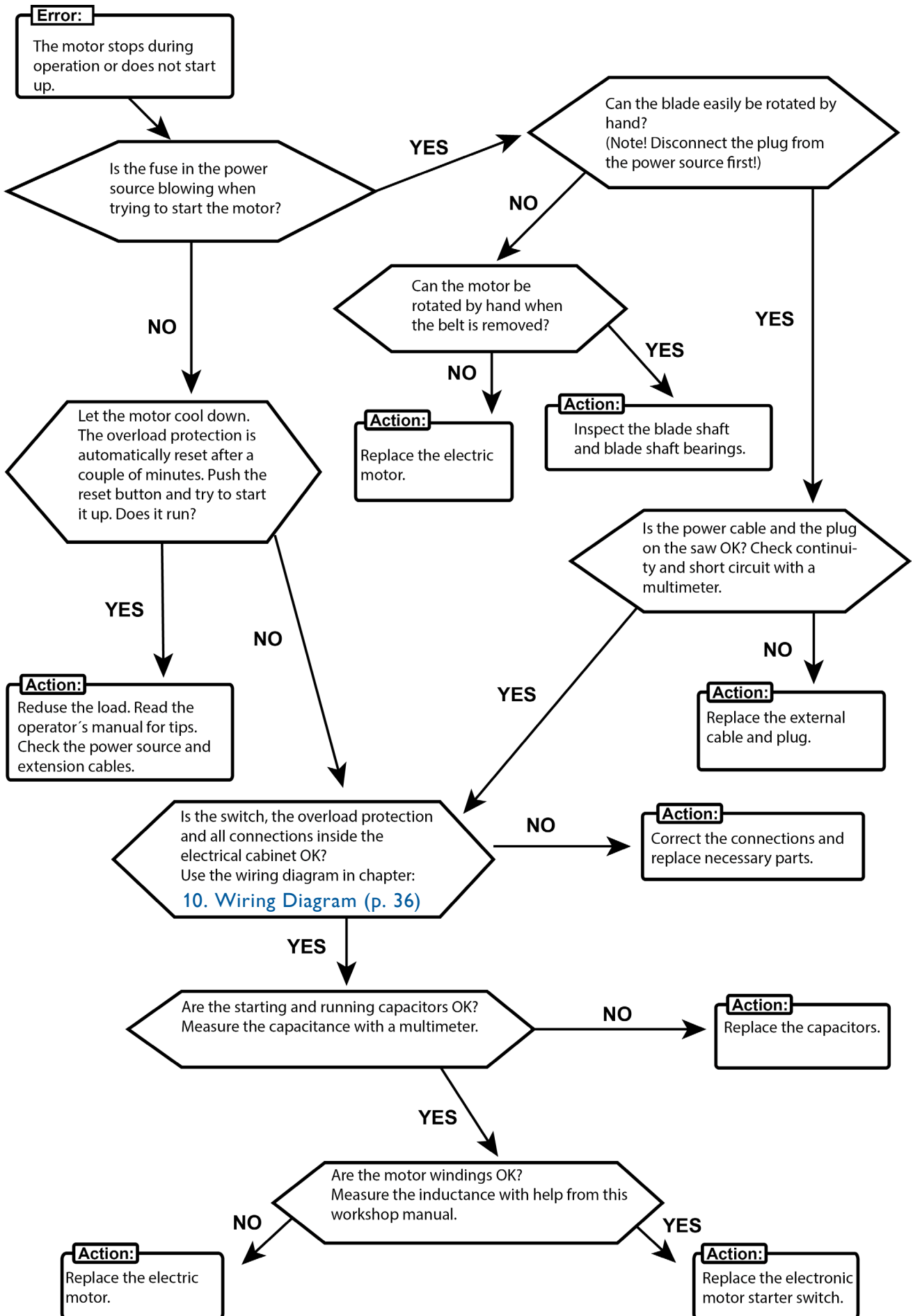

## 8. REPAIR INSTRUCTIONS

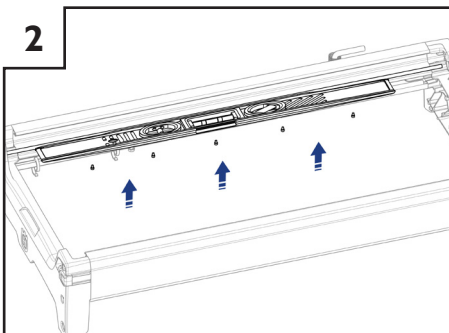
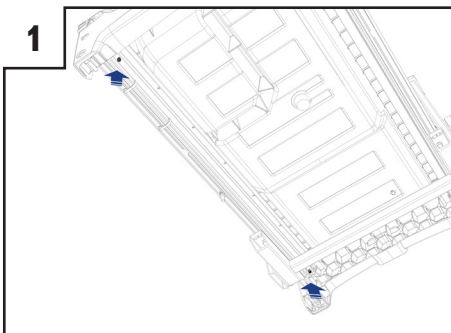
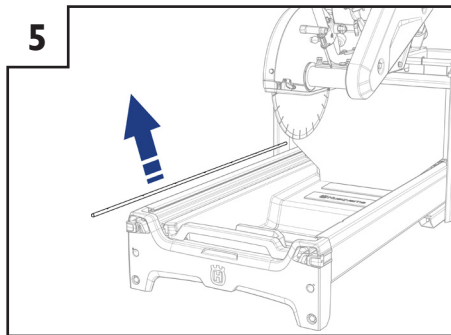
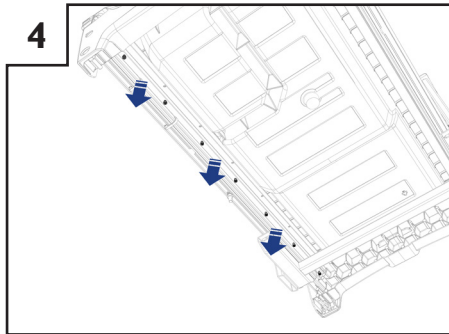
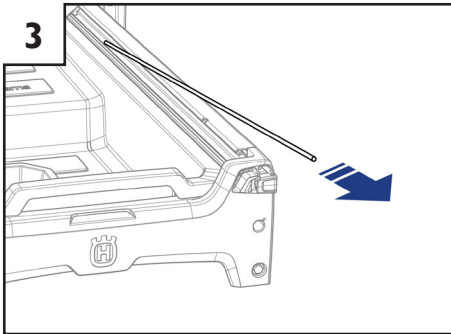
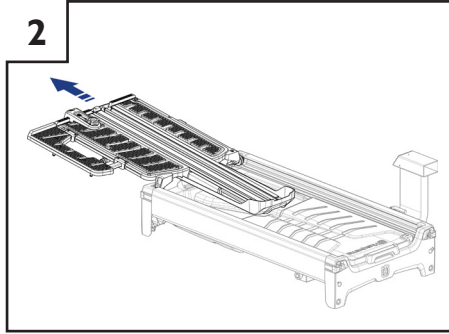
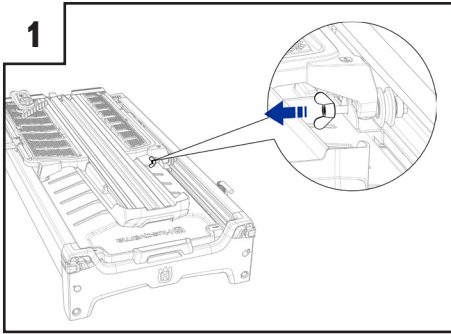

## Remove the conveyor cart steel rods



1. Unscrew the wing nut underneath the conveyor cart to remove the cable bracket.
2. Remove the conveyor cart from the frame.
3. The steel rod on the right hand side is loose and lies in a track. Lift it out.
4. To remove the steel rod on the left hand side, remove the 7 screws under the frame.
5. Lift out the steel rod.

## Mount the conveyor cart steel rod.

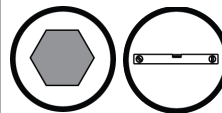

1. Put the steel rod in place and tighten the 2 outer screws. Put the 5 middle screws in place without tightening them.
2. Use a spirit-level, to set the steel rod straight and tighten the 5 middle screws.



**Attention!** Adjust the steel rod carefully. The saw will make bad cuts if the rod is not perfectly aligned.

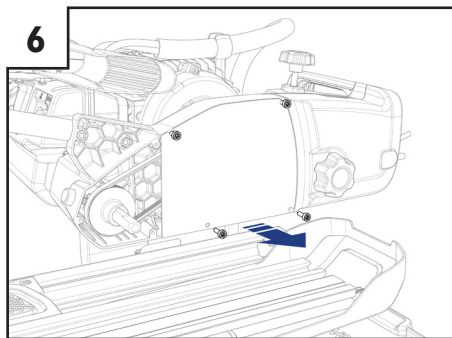
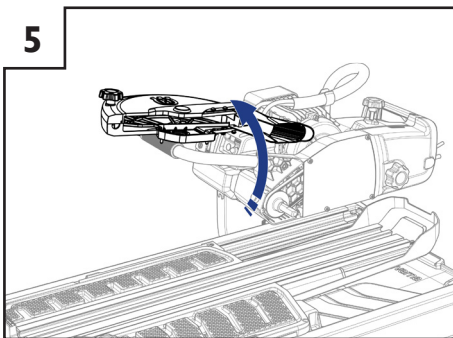
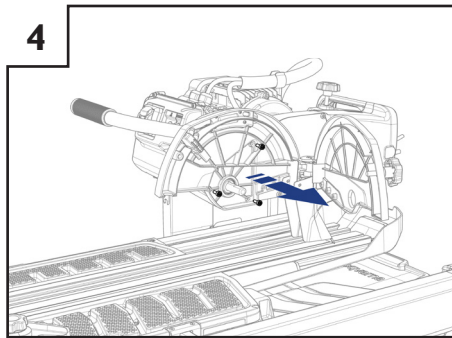
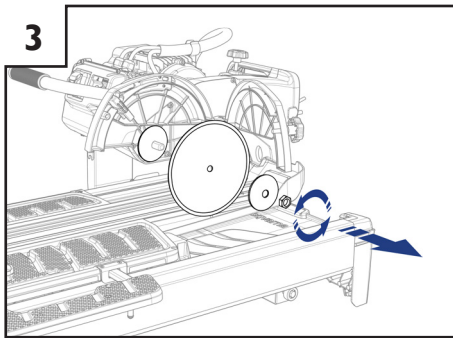
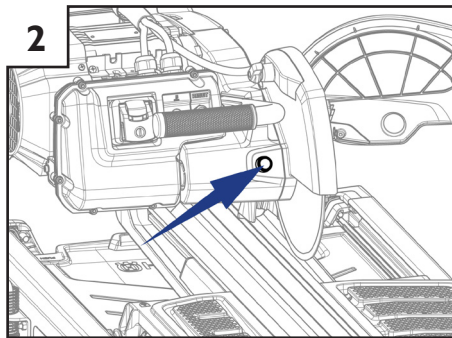
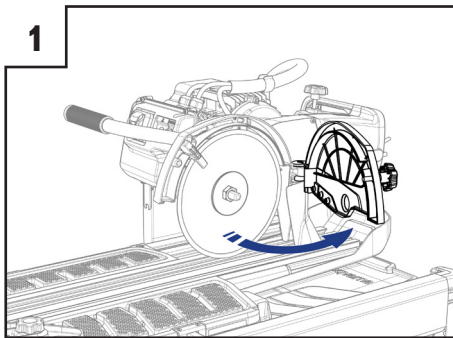

## Remove the blade guard and belt cover

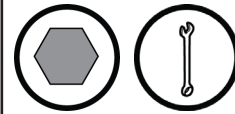

1. Open the blade guard.
2. Press the blade shaft lock button.
3. Remove the blade nut, blade and flanges.
4. Unscrew the three screws holding the inner blade guard.
5. Put the inner blade guard on top of the connection box.
6. Loosen the two top screws and unscrew the two bottom screws completely to remove the belt cover.

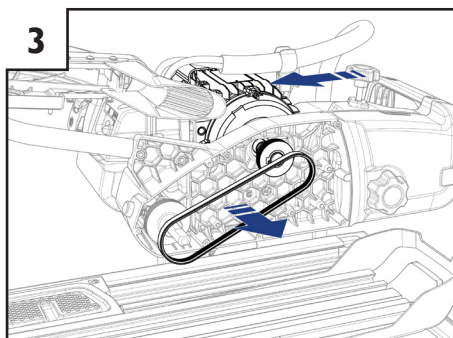
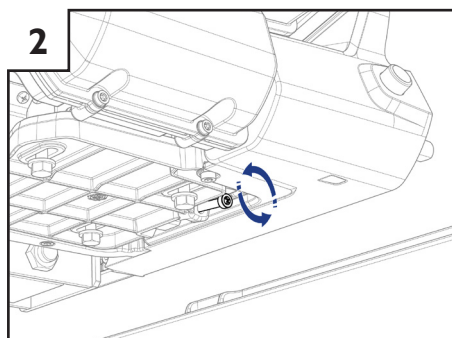
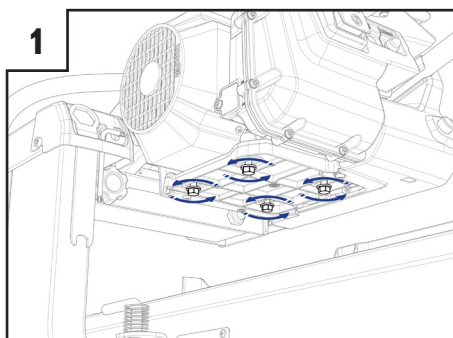

## Remove the Belt

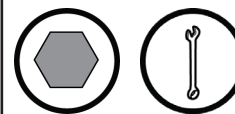

First see: [Remove the blade guard and belt cover \(p. 13\)](#)

1. Loosen the four screws holding the motor to the bracket.
2. Release the belt tension by unscrewing the belt tension adjusting screw underneath the motor.
3. Pull the motor towards the operator to loosen the belt tension, then remove the belt.

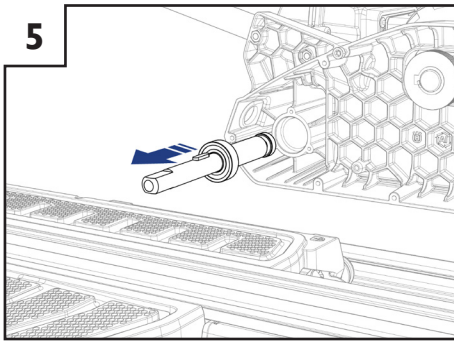
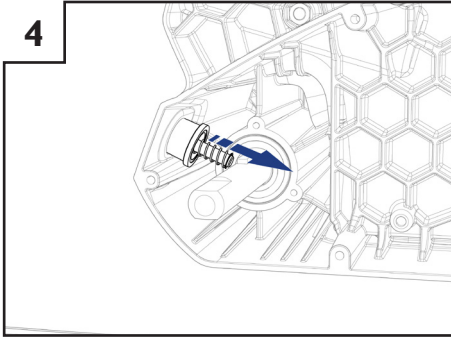
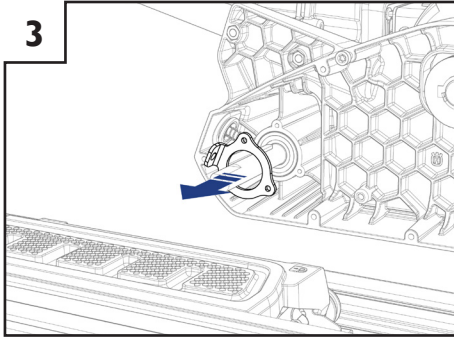
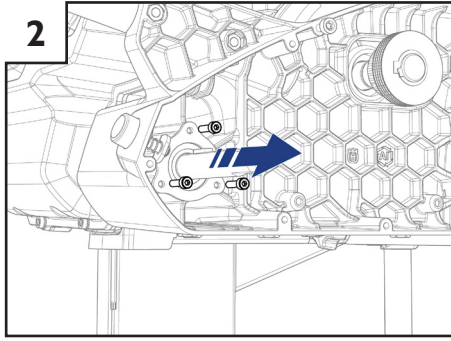
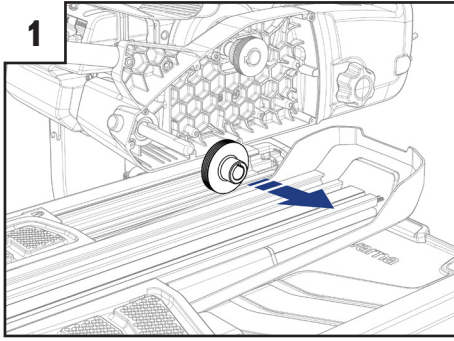

## Remove the Blade Shaft



First see: [Remove the blade guard and belt cover \(p. 13\)](#) and [Remove the Belt \(p. 13\)](#)

1. Remove the blade shaft pulley. It should be loose on the shaft, but use a puller if necessary.
2. Unscrew the three screws holding the blade shaft flange.
3. Remove the blade shaft flange.
4. Remove the blade shaft lock button.
5. Pull the blade shaft and bearing out.

Reverse steps for assembly.

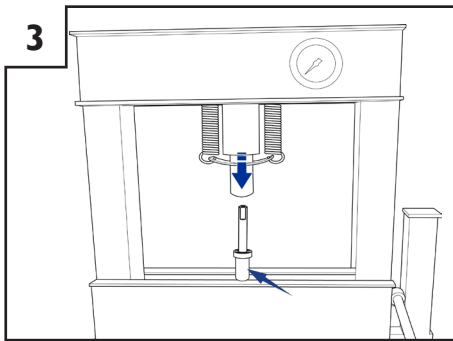
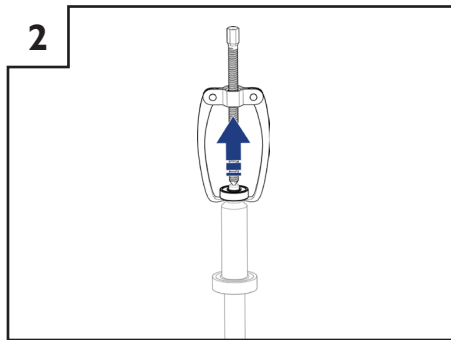
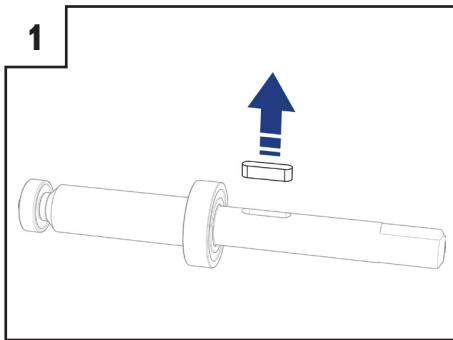

## Replace Blade Shaft Bearings

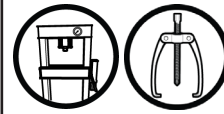

First see: **Remove the blade guard and belt cover (p. 13)**, **Remove the Belt (p. 13)** and **Remove the Blade Shaft (p. 14)**

1. Remove the key from the blade shaft.
2. Use a puller to remove the small bearing.
3. Put the shaft in a workshop press to press the blade shaft out from the bearing. Use a collar as an anvil.

**Note!** Always use a collar to press on the inner ring of the bearings when assembling them on the blade shaft.

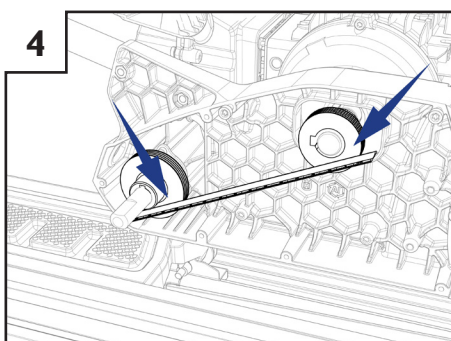
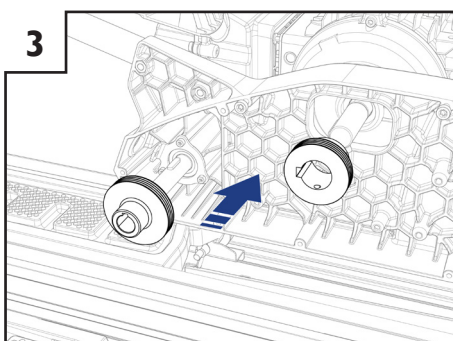
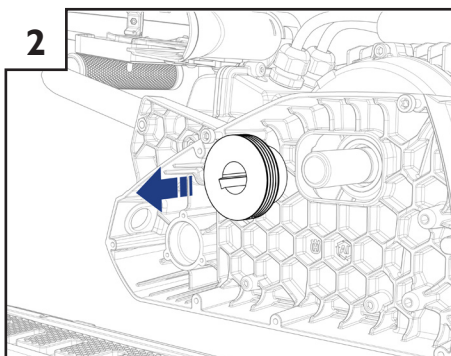
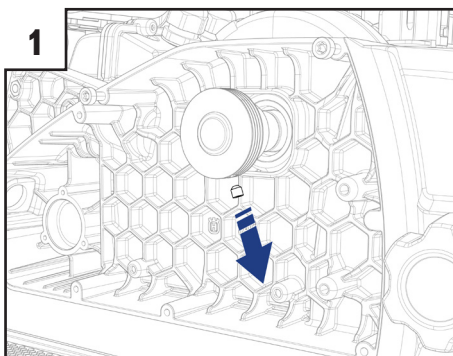

## Replace the Pulleys

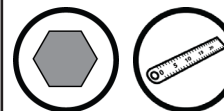

First see: **Remove the blade guard and belt cover (p. 13)** and **Remove the Belt (p. 13)**

1. Unscrew the set screw holding the motor shaft pulley.
2. Remove the motor shaft pulley.
3. Put the pulleys back on the shafts.
4. Make sure the blade shaft pulley is in its inner position. Use a ruler to ensure the pulleys are aligning and then put thread locking compound on the motor shaft pulley's set screw and tighten it.

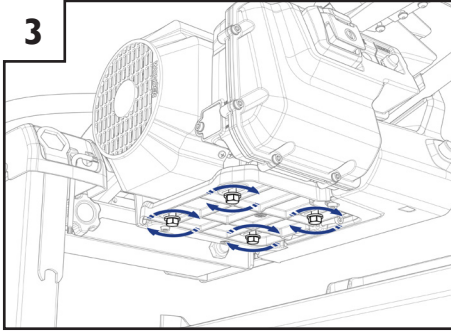
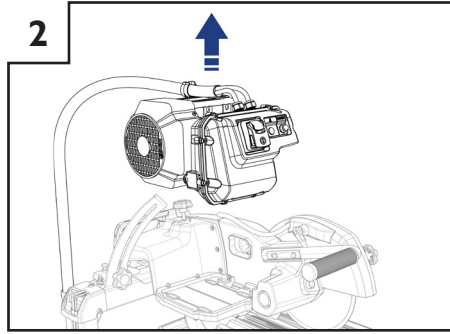
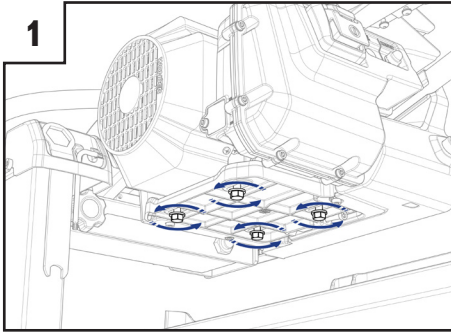

## Motor replacement

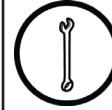

First see: **Remove the Belt (p. 13)** and **Replace the Pulleys (p. 15)** to remove the pulley on the motor shaft.

1. Remove the 4 screws underneath the motor holding the motor to the bracket.
2. Lift out the motor. It is still attached to the motor mounting plate and the connection box. The power and water pump cables can be left connected to the connection box.
3. Mount the replacement motor with the 4 screws to the bracket.

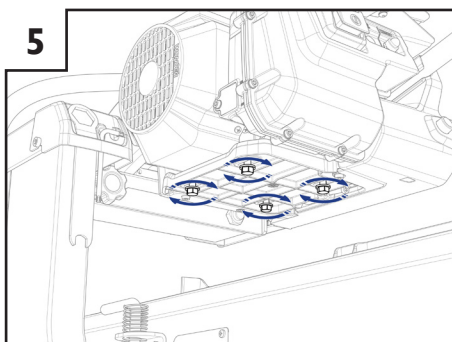
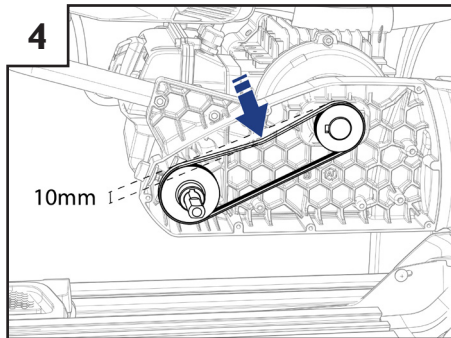
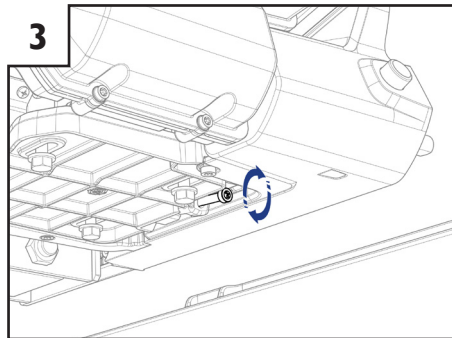
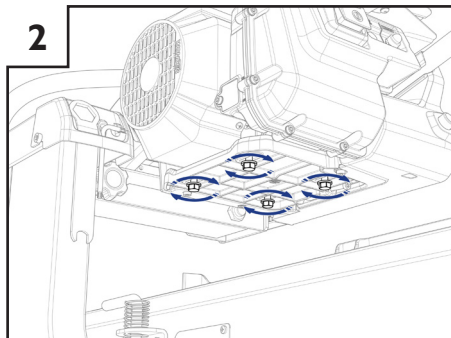
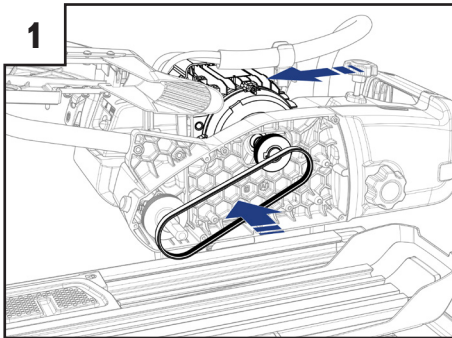

## Mount the Belt

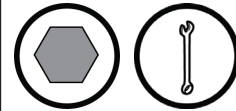

First see: [Remove the Belt](#) (p. 13)

1. Pull the motor towards the operator to be able to fit the belt.
2. Gently tighten the 4 screws holding the motor.
3. Adjust the belt tension with the adjusting screw underneath the motor.
4. The belt is sufficiently tensioned when it can be pressed down about 10 mm with a normal finger pressure.  
The best way to achieve a correct belt tension is by snapping the belt and measure its frequency with a sonic tension meter. The frequency should be 190Hz ±10.
5. Tighten the 4 screws holding the motor to the bracket.

**Note!** Make sure the pulleys are parallel with help from a ruler after the motor has been tightened.

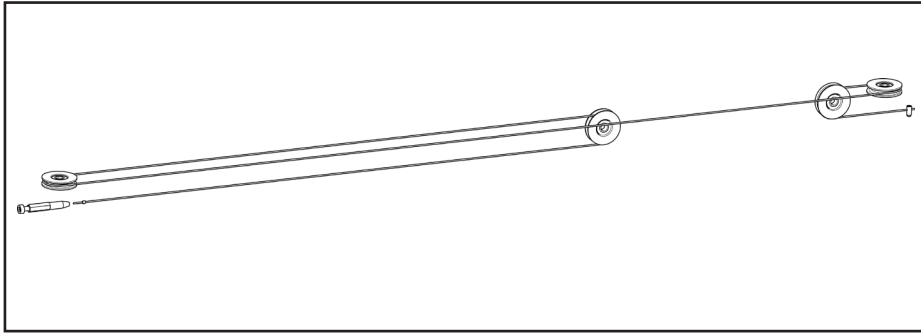

### Removing the Conveyor Cart/Support Arm Cable (Only TS90)

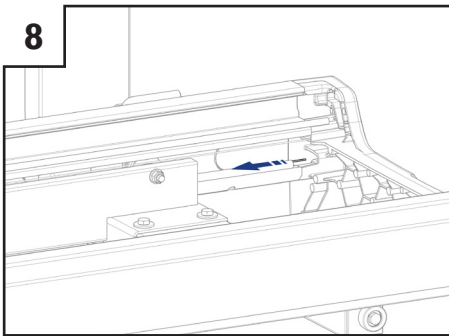
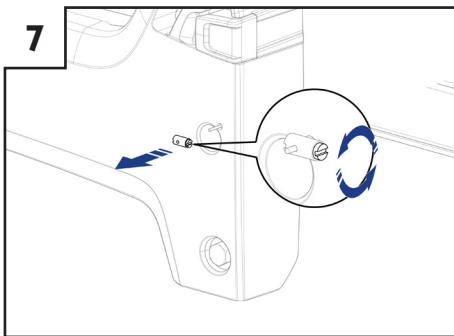
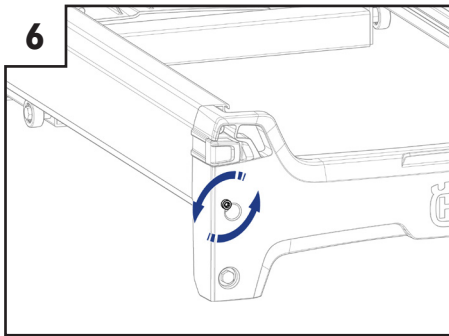
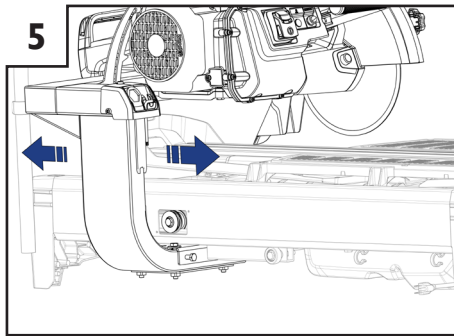
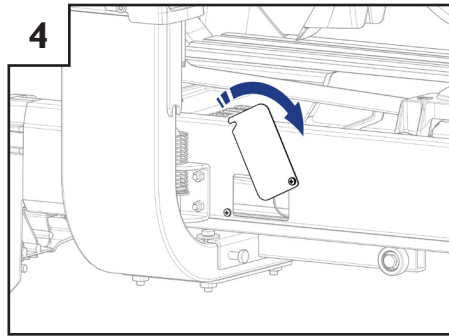
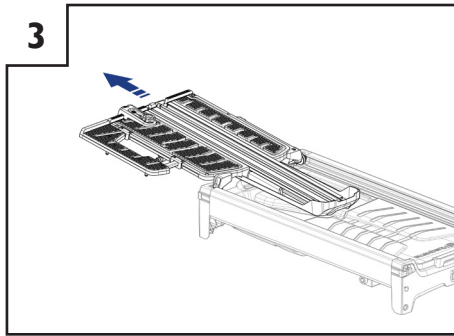
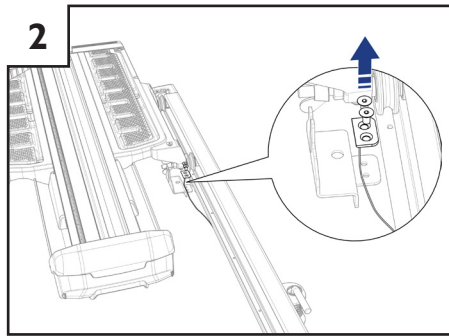
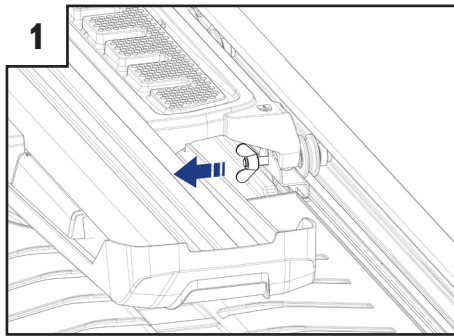
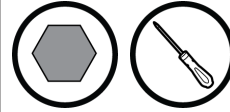

1. Unscrew the wing nut underneath the conveyor cart to remove the cable bracket.
2. Unscrew the two screws holding the bracket to the cable, then remove the bracket.
3. Remove the conveyor cart from the frame.
4. Open the service hatch on the left hand side of the frame.
5. Move the saw arm so the cable wheel that is farthest away from the operator is in front of the service hatch.
6. Loosen the cable tension fully by unscrewing the cable tension screw.  
The screw is positioned on the left hand side of the frame, closest to the operator.
7. Remove the solderless pear nipple from the conveyor cart cable.  
The solderless pear nipple is positioned on the left hand side of the frame, farthest from the operator.
8. Pull out the loose cable end from the hole in the frame.

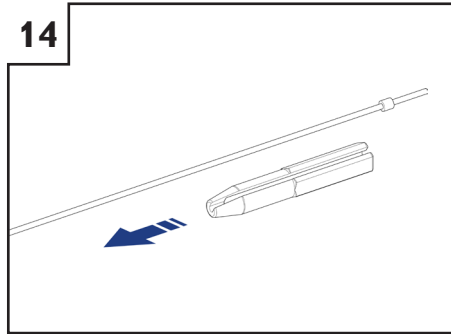
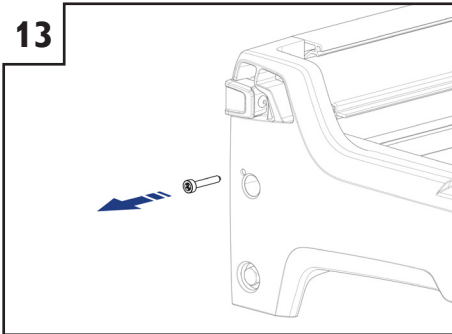
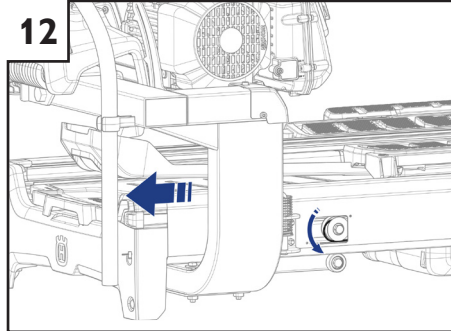
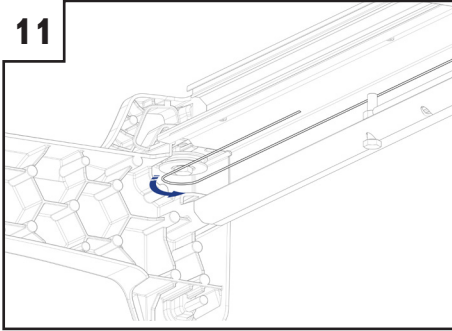
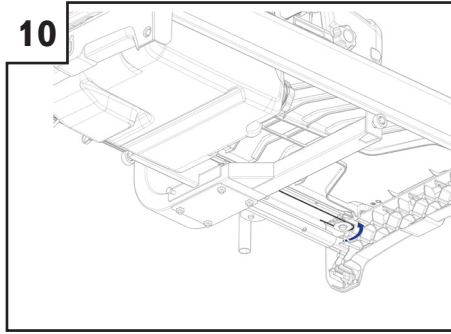
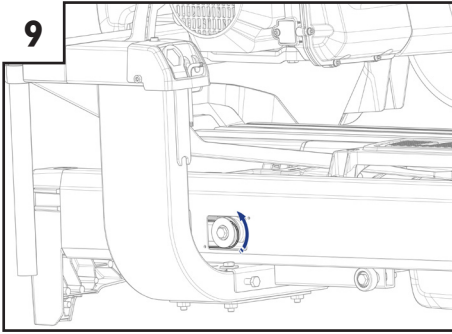

9. Remove the cable from the cable wheel on the support arm farthest from the operator via the service hatch
10. Remove the cable from the wheel that is in the left corner, farthest from the operator.
11. Remove the cable from the cable wheel that is in the left corner, closest to the operator.
12. Move the saw arm to remove the cable from the cable wheel on the support arm closest to the operator via the service hatch.
13. Remove the cable tension screw.
14. Remove the cable lock from the cable.

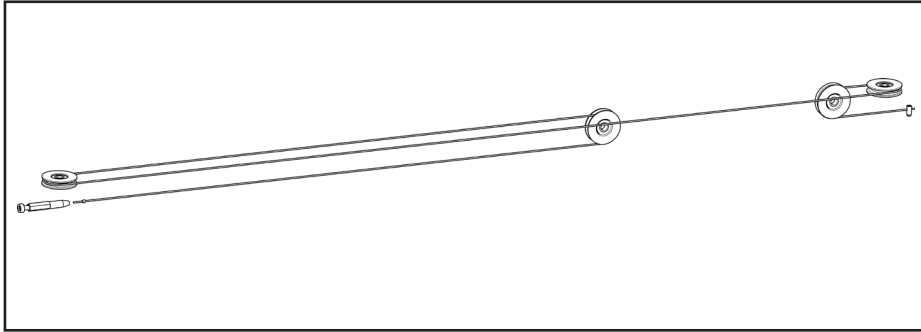

### Mount the Cart/Support Arm Cable (Only TS90)

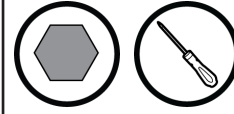

First see: [Removing the Conveyor Cart/Support Arm Cable \(Only TS90\) \(p. 18\)](#)

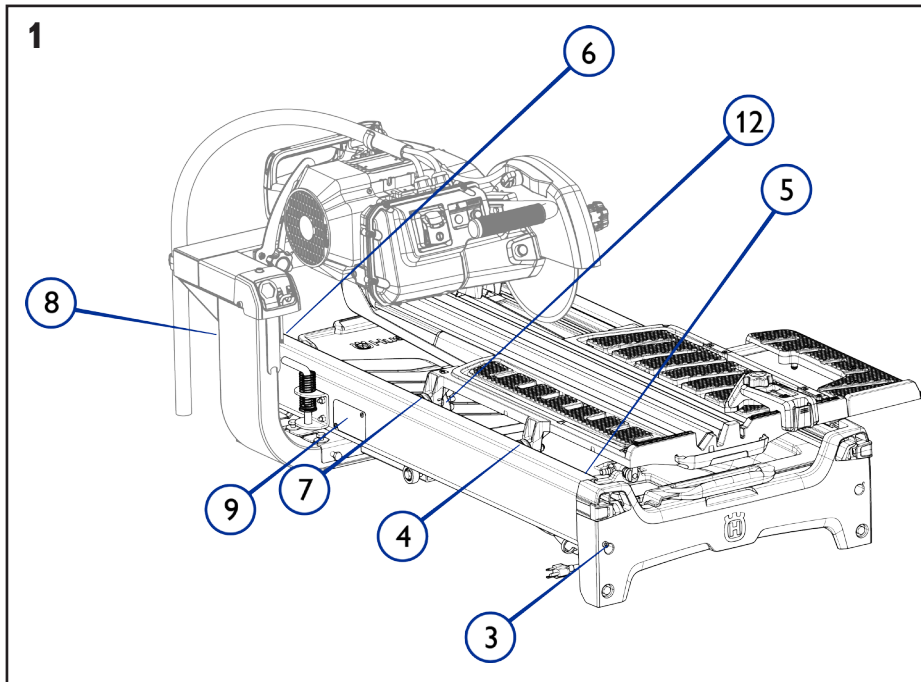

1. This overview picture shows where to find each close-up service step in this chapter.
2. Mount the new cable in the cable lock.
3. Attach the cable and cable lock with the tension screw by tightening the screw 4 turns.
4. Position the support arm so that the support arm wheel closest to the operator is visible behind the service hatch
5. Thread the cable around the wheel mounted in the frame closest to the operator.

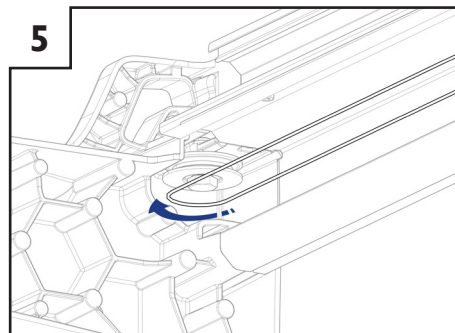
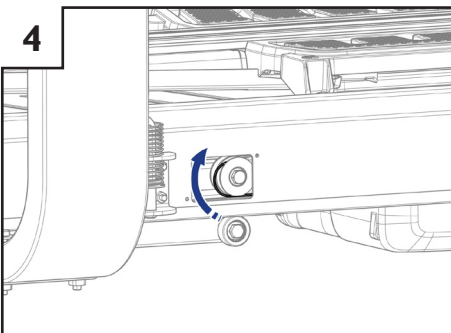
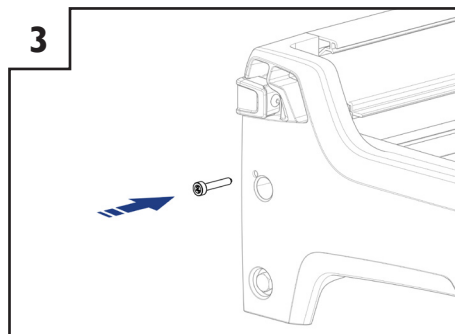
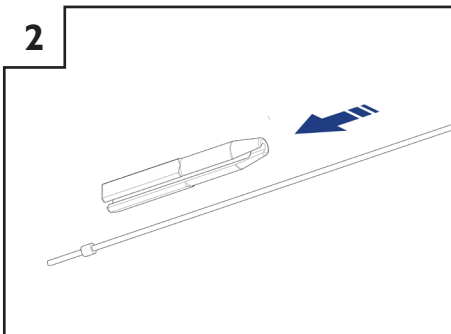

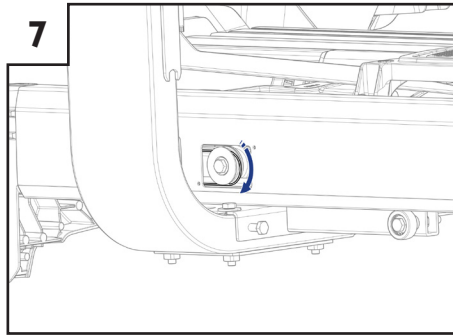
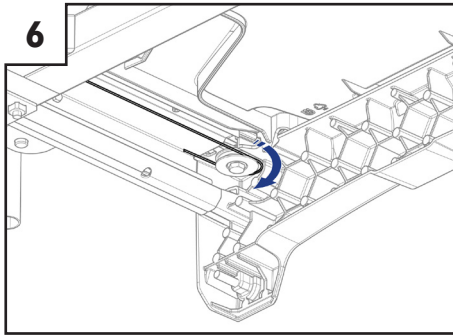

6. Thread the cable around the wheel mounted in the frame farthest away from the operator.

7. Position the support arm so that the support arm wheel farthest away from the operator is visible behind the service hatch. Then thread the cable.

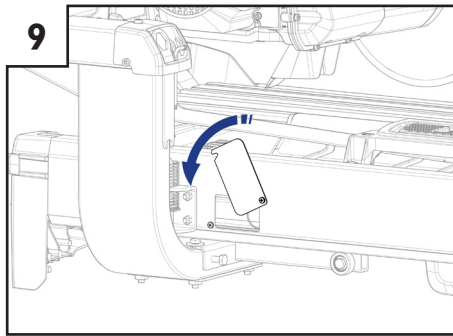
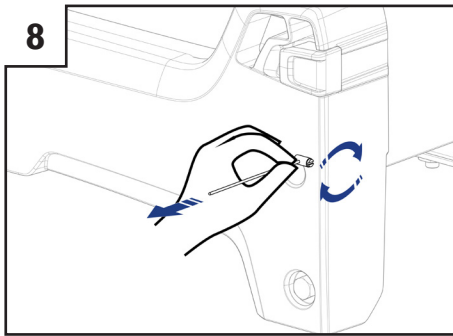

8. Pull out the cable through the hole on the backside of the frame. Mount the solderless pear nipple and tighten the cable by hand to remove the slack, then tighten the screw.

9. Mount the service hatch.

10. Put back the conveyor cart in the frame.

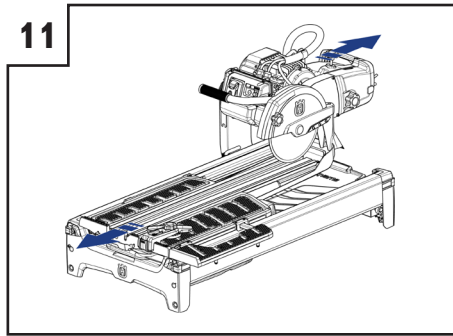
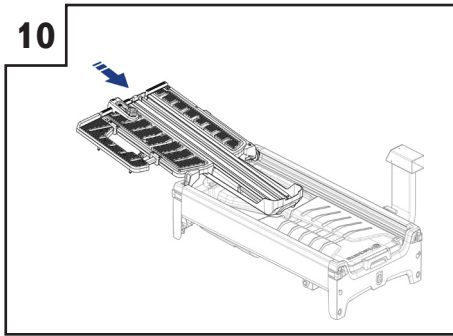

11. Move the conveyor cart as close to the operator as possible and the support arm as far away as possible.

12. Mount the bracket to the cable. The cable should be threaded in an S-shape around the screws.

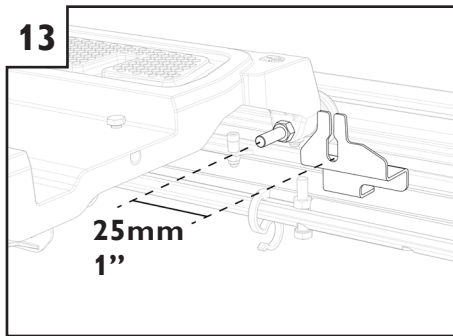
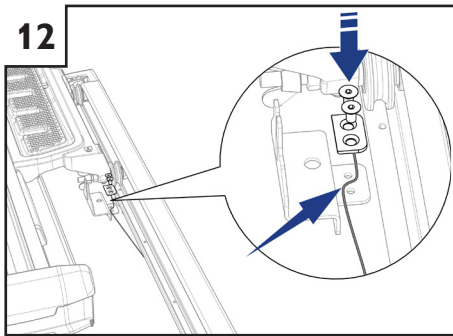

13. Tighten the bracket to the cable approximately 1 inch or 25 millimetres in front of the screw holding the bracket.

14. Mount the bracket with the wing nut.

15. Tighten the cable tension screw approximately 4-5 turns until the conveyor cart and support arm moves without too much friction or play.

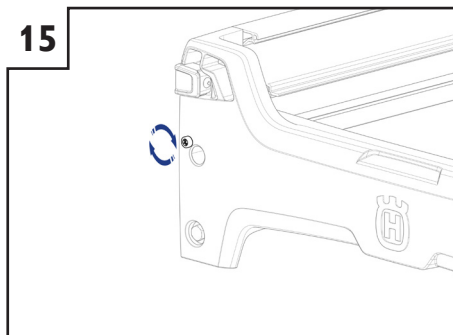
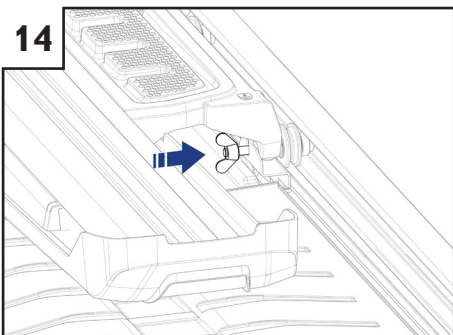

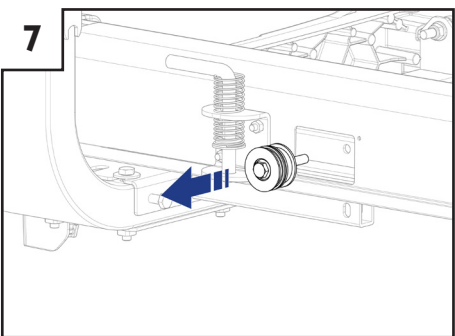
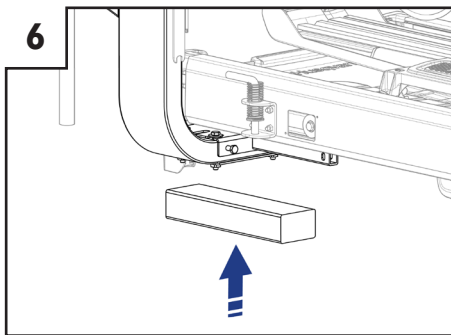
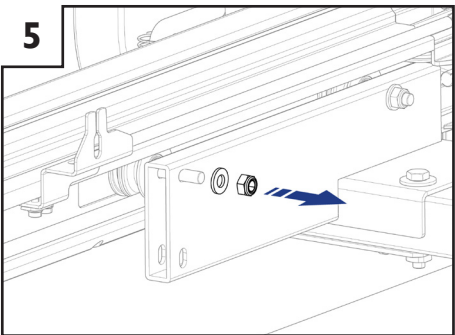
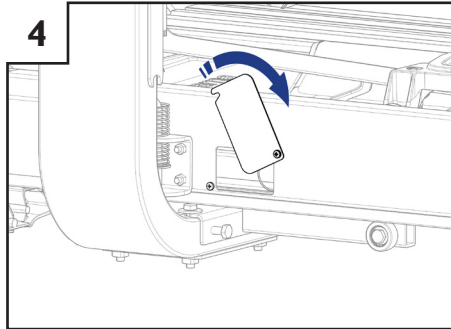
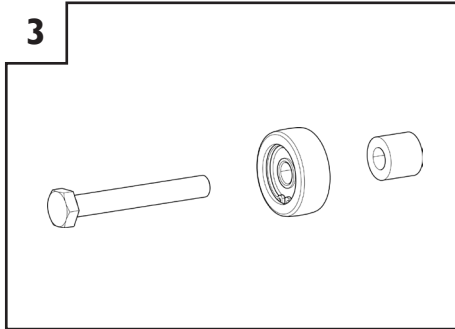
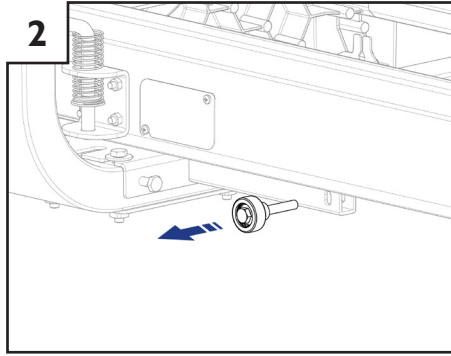
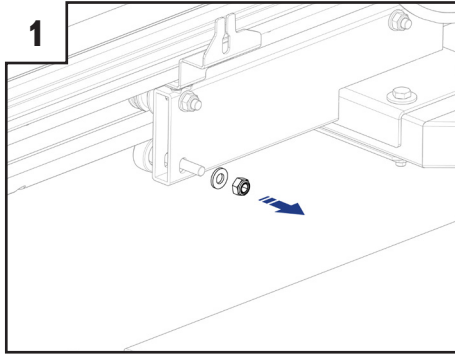

### Replace the Support Arm Wheels and Bearings (Only TS90)



1. Remove the nut and washer holding the lower support arm wheel closest to the operator.
2. Remove the screw and support arm wheel.
3. Exploded view of the support arm wheel.
4. Open the service hatch on the left hand side of the frame.
5. Position the support arm so that the wheel closest to the operator is visible behind the service hatch. Then remove the nut and washer.
6. To remove the upper front support arm wheel, put something under the support arm to relieve the pressure from the wheel.
7. Remove the screw and support arm wheel.

Reverse steps for assembly.

Use the same technique on the other support arm wheels.

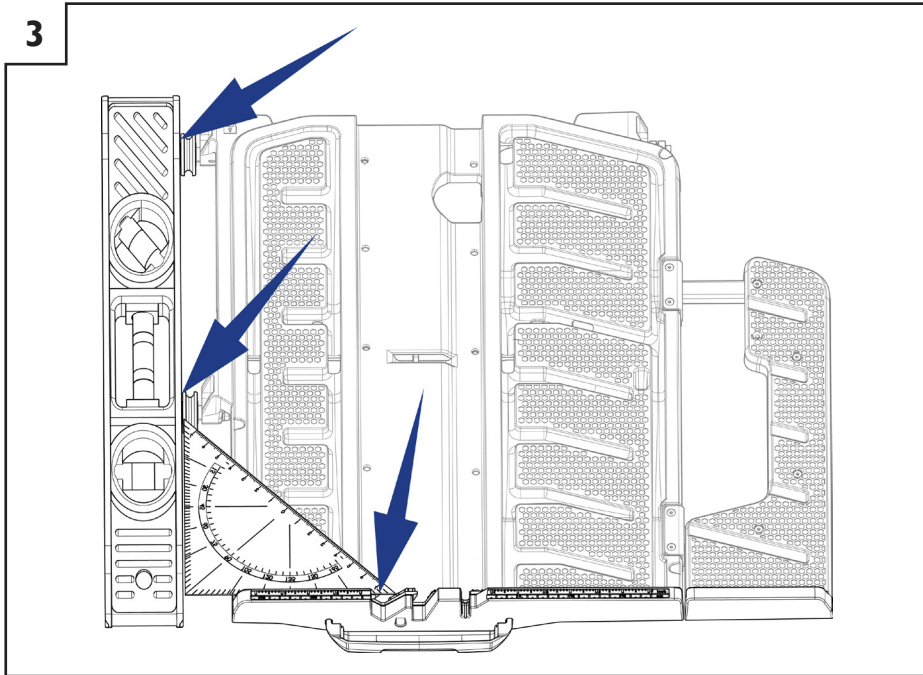
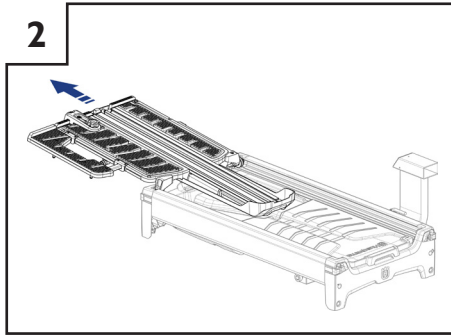
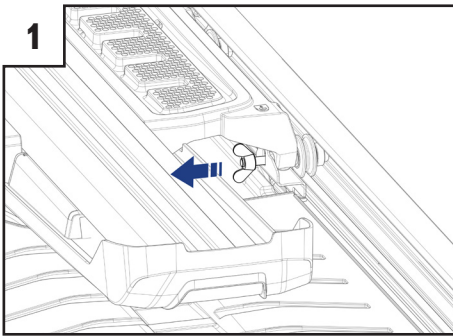

## Measure/Adjust the Conveyor Cart Wheel Traction

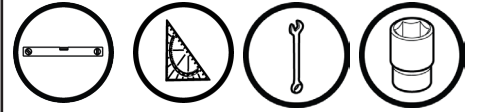

1. Unscrew the wing nut underneath the conveyor cart to remove the cable bracket (Only TS90)
2. Remove the conveyor cart from the frame.
3. Ensure that the conveyor cart wheels are perpendicular to the conveyor cart anvil as illustrated.

If NOT, take one of the following actions:

- Replace one of the conveyor cart wheels and check the perpendicularity again.
- Shim one of the conveyor cart wheels to adjust its side position.

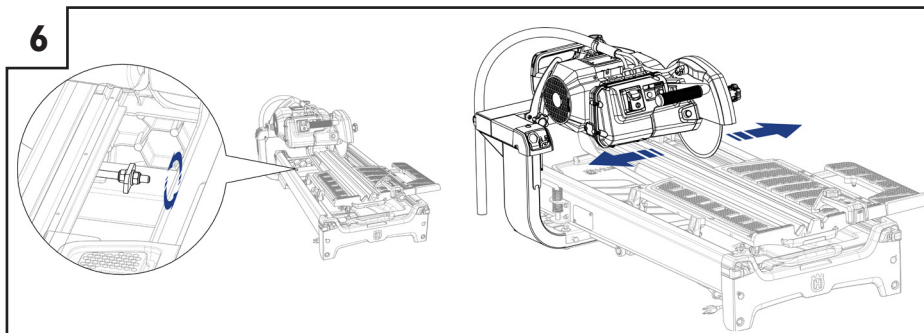
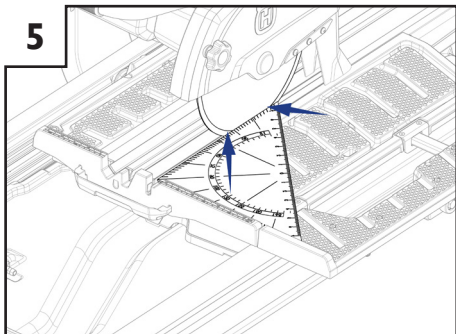
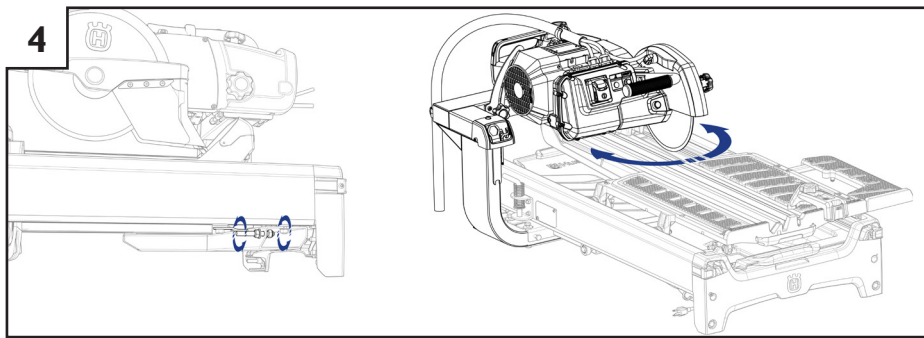
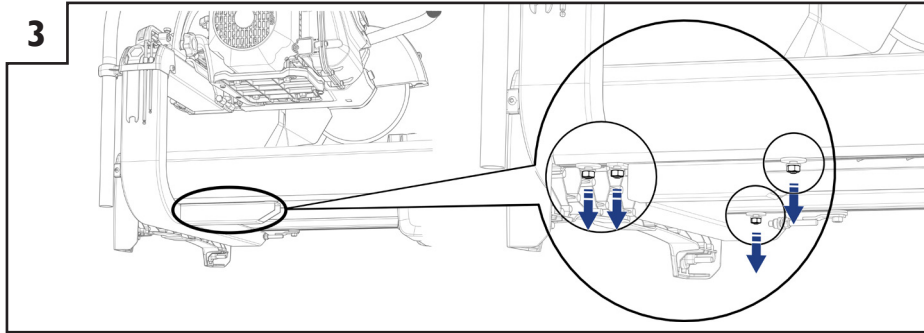
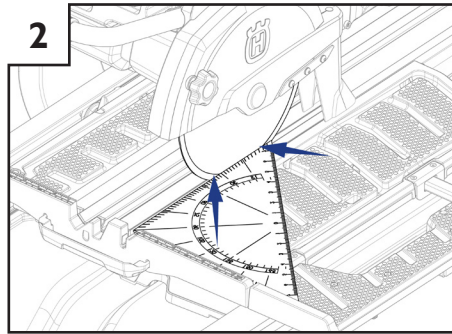
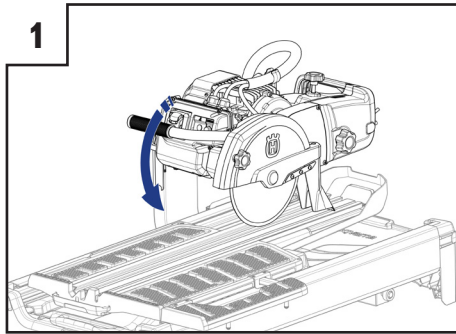

### TS70 - Setting the blade parallel and in center of the cutting slot.



1. Set the blade to its lowest position. The blade should run freely in the cutting slot.
2. Check with a set square or an angel if the blade is perpendicular to the conveyor cart anvil and in centre of the cutting slot. Hold the set square against 2 points of the cutting surface on the blade to get the right measurements.
3. To adjust the blade, loosen the 4 nuts on the bottom of the support arm.
4. Adjust the screw on the right hand side of the machine to get the blade perpendicular to the conveyor cart anvil.
5. Check the perpendicularity between the blade and cutting slot with an set square.
6. Adjust the side position screw underneath the cart to move the blade sideways.

7

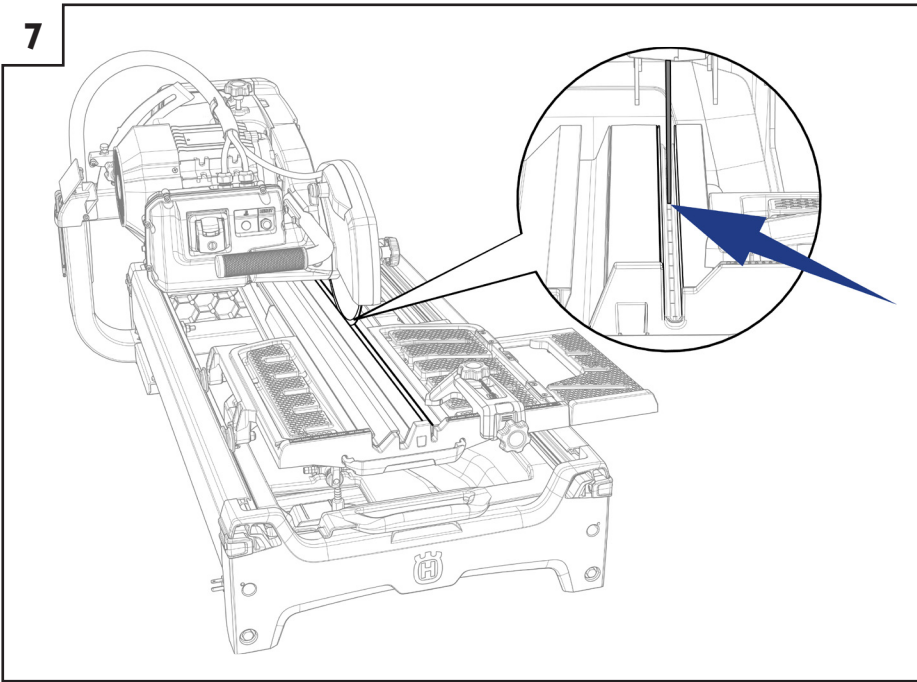

7. Check that the blade is in the centre of the cutting slot.
8. Tighten the adjustment rod and the 4 screws holding the support arm when the blade is in the center of the cutting slot and perpendicular to the conveyor cart anvil.

**NOTE!** If the blade is not parallel to the cutting slot the object being cut might crack instead of being cut off.

8

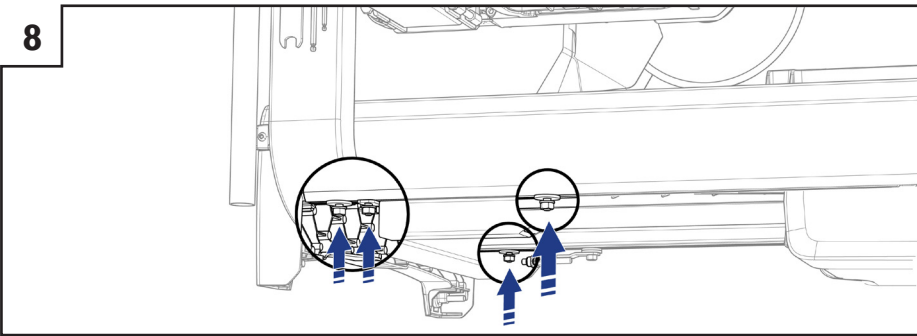

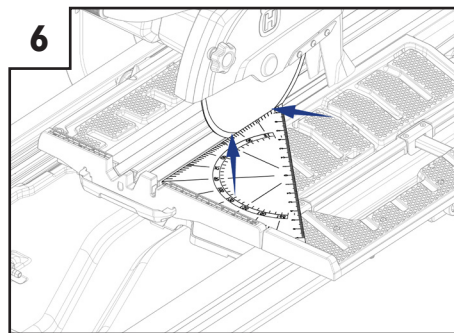
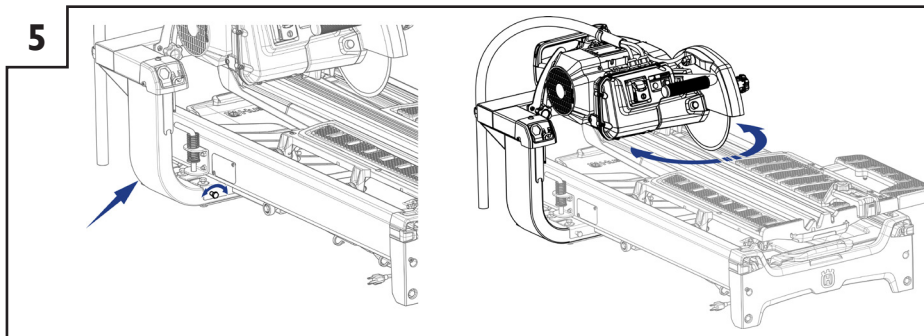
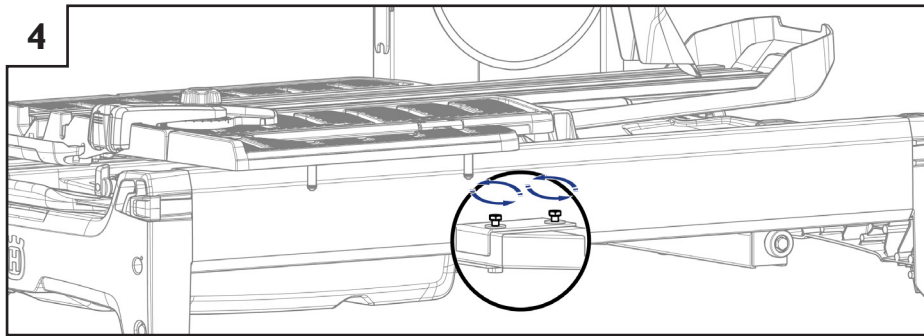
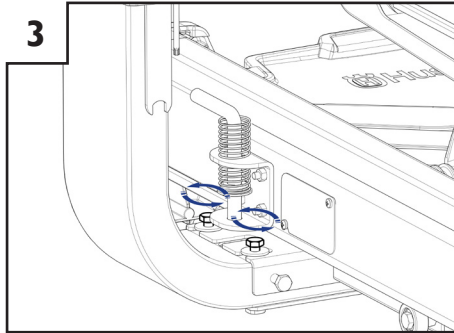
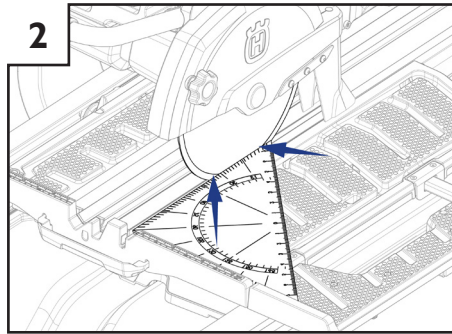
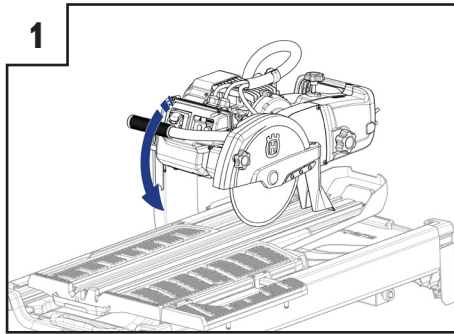

**TS90 - Setting the blade parallel and in center of to the cutting slot**



1. Set the blade to its lowest position. The blade should run freely in the cutting slot.
2. Check with a set square or an angel if the blade is perpendicular to the conveyor cart anvil and in centre of the cutting slot. Hold the set square against 2 points of the cutting surface on the blade to get the right measurements.
3. To adjust the blade, loosen the 2 screws holding the support arm.
4. Then loosen the two support arm screws on the inside of the frame.
5. Set the blade angle with the two adjusting screws on the support arm on left hand side of the saw to get the blade perpendicular to the conveyor cart anvil.
6. Check the perpendicularity between the blade and cutting slot with a set square.

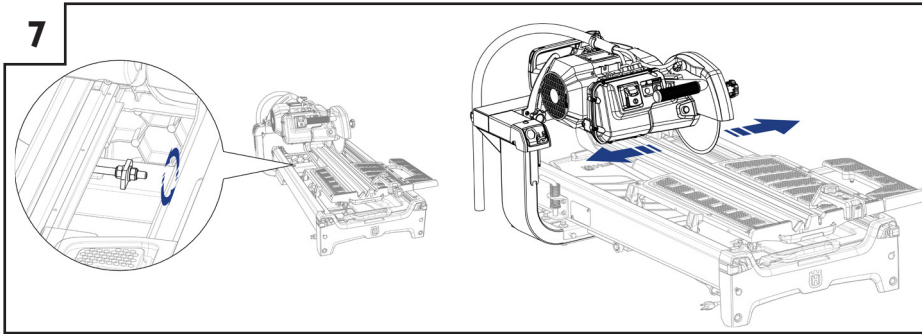

7. Adjust the side position screw underneath the cart to move the blade sideways.

8. Check that the blade is in the centre of the cutting slot.

9. Tighten the 4 screws holding the support arm when the blade is in the center of the cutting slot and perpendicular to the conveyor cart anvil.

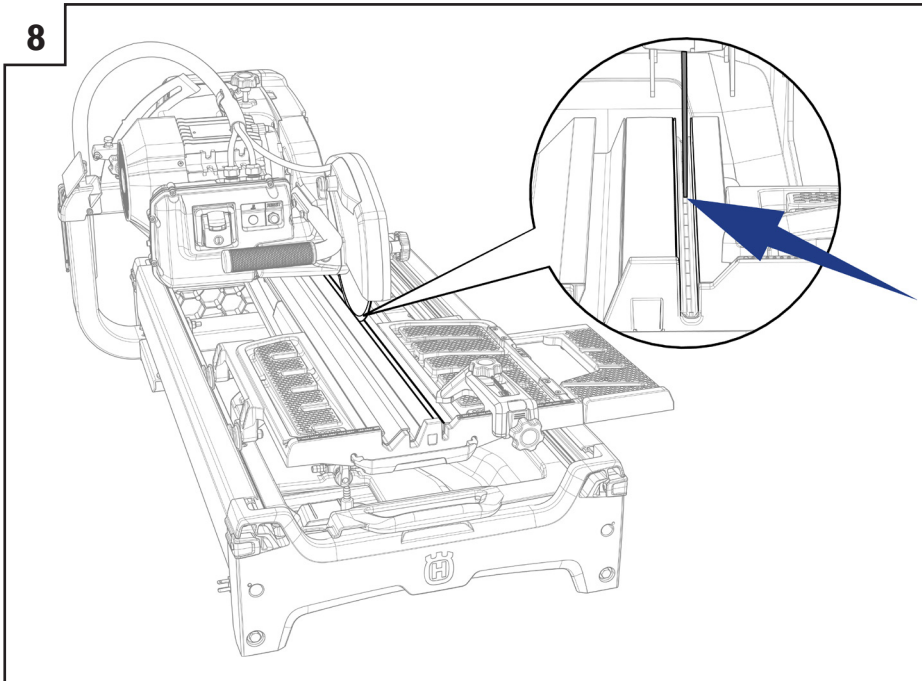

**NOTE!** If the blade is not parallel to the cutting slot the object being cut might crack instead of being cut off.

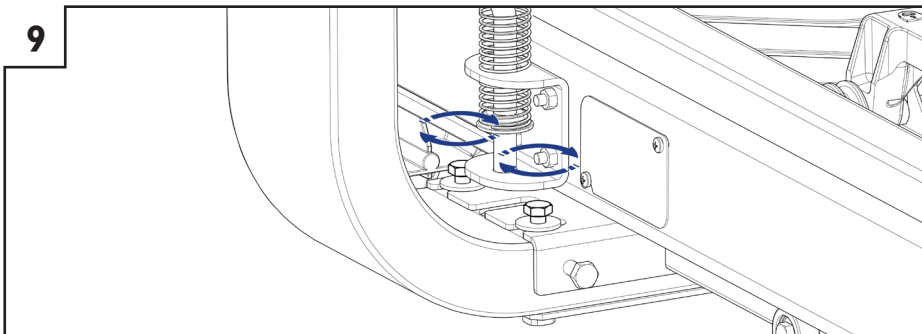

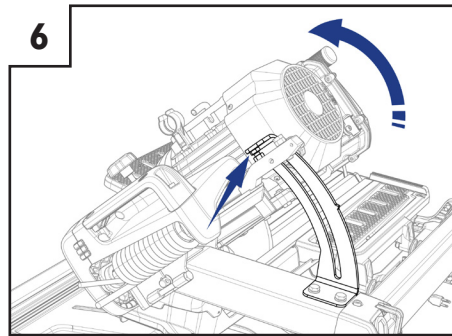
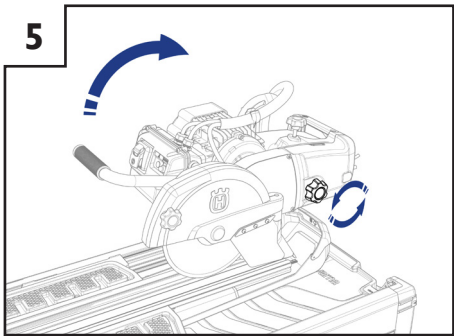
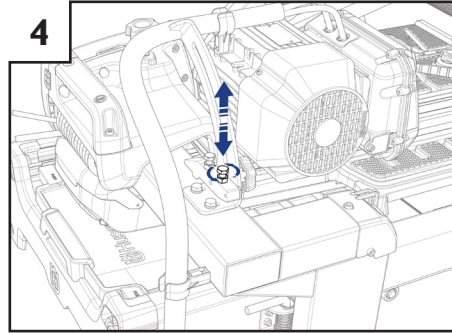
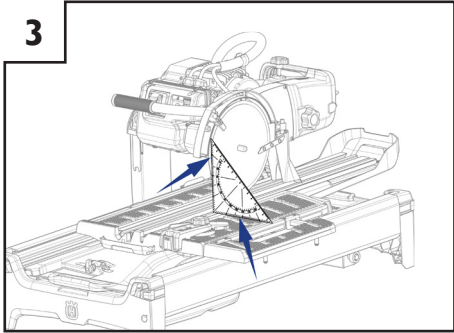
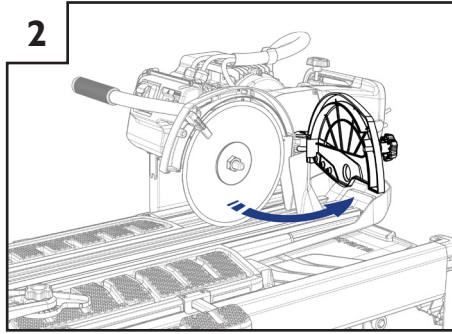
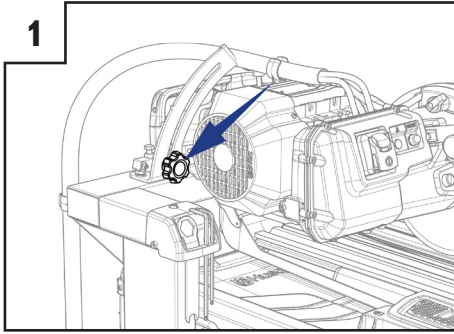

### Setting the Blade angles to the conveyor cart surface.



#### 90° position:

1. Loosen the locking knob for mitre cutting and set to the 90° cutting position.
2. Open the blade guard.
3. Use a angel to verify if the blade is perpendicular to the conveyor cart surface.

Hold the set-square against the cart surface and against two points of the blade.

4. Loosen the lock nut and adjust the screw until 90° angle between the blade and cart surface is achieved. Then tighten the lock nut.

#### 45° position:

5. Loosen the locking knob for depth setting and raise up the cutting arm.
6. Set the saw in 45° mitre cutting position. The screw head in the picture should touch the console.

7

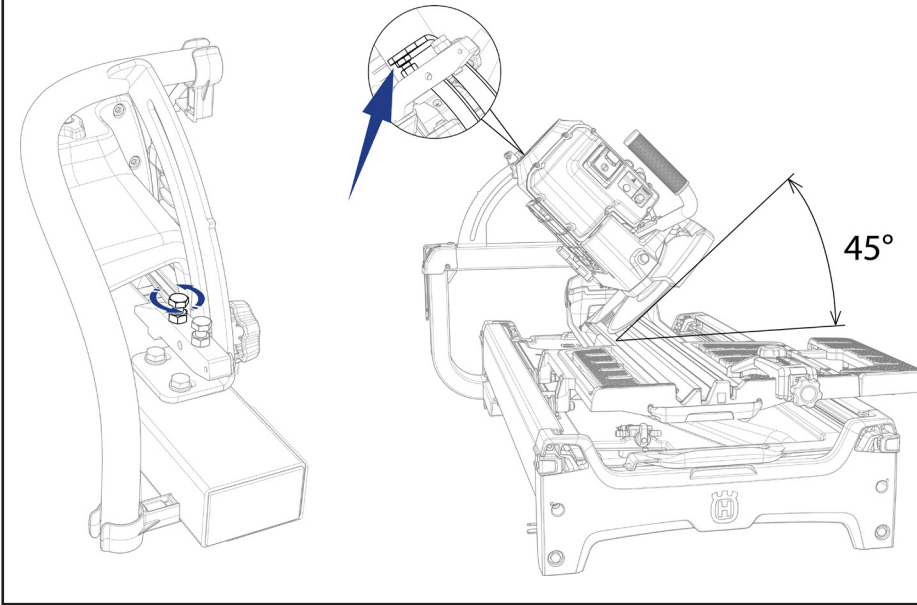

7. Adjust the inner screw until 45° angle between the blade and cart surface is achieved, then tighten the lock nut.

**22,5° position:**

8. Set the saw to 22,5° mitre cutting with help from the markings. Move the triangular shaped marking if necessary to achieve 22,5° between the blade and the cart surface.

8

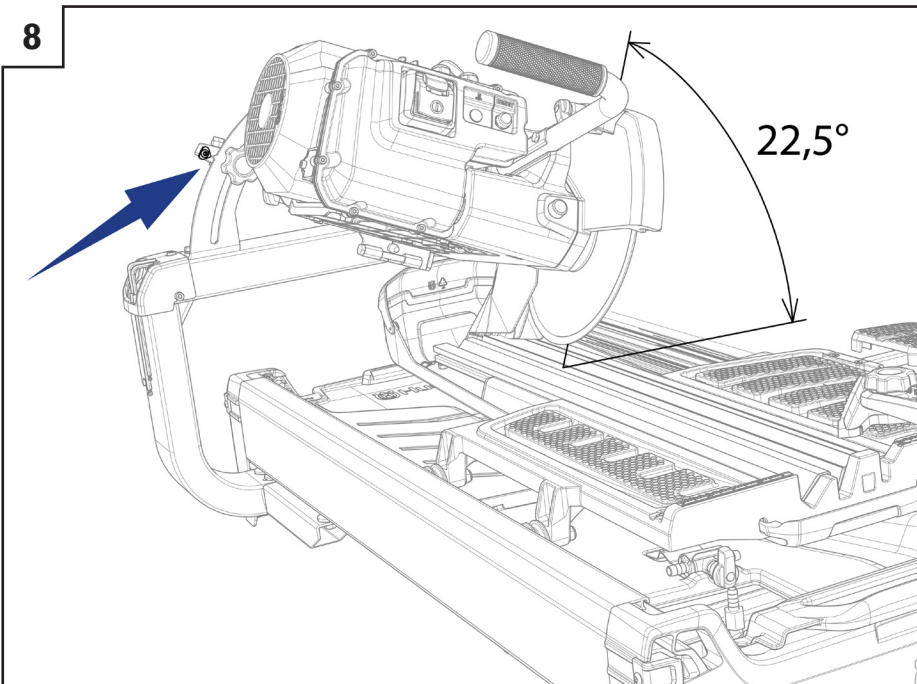

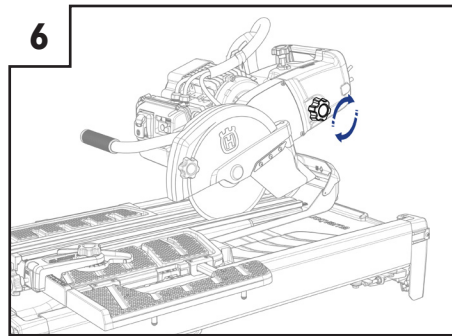
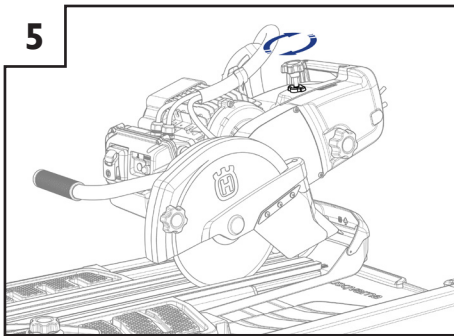
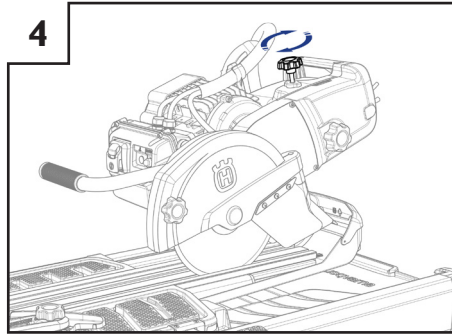
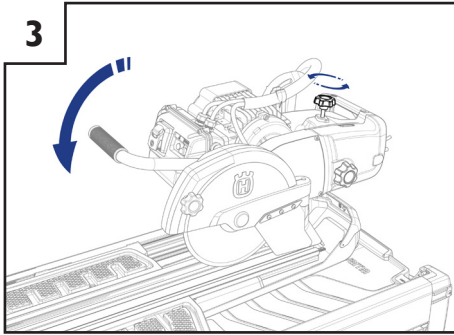
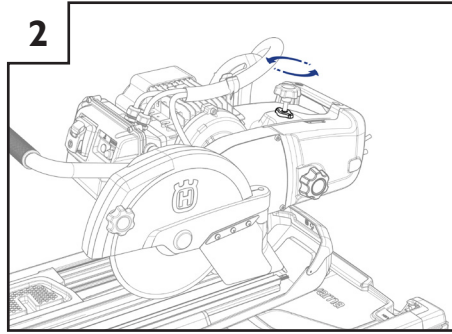
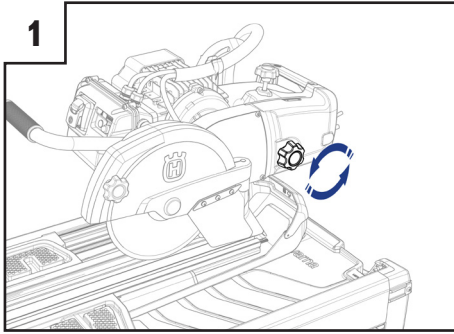

### Setting the depth stop for the blade.

1. Loosen the locking knob for depth setting.
2. Loosen the lock nut.
3. Loosen the depth stop adjustment knob. Push down the cutting arm until the blade hits the bottom of the slot in the cart.
4. Hold down the cutting arm in this position. Screw down the knob for setting the stop depth until the end of the knob abuts the underlying surface in order to set up the stop depth of the blade. Turn another turn to raise the head from the cart slightly.
5. Tighten the locking nut.
6. Tighten the locking knob for depth adjustment with the cutting arm still pushed down to its lowest position.  
Check the position of the blade by moving the conveyor cart to its forward and rear end position. The blade should never hit the cart.

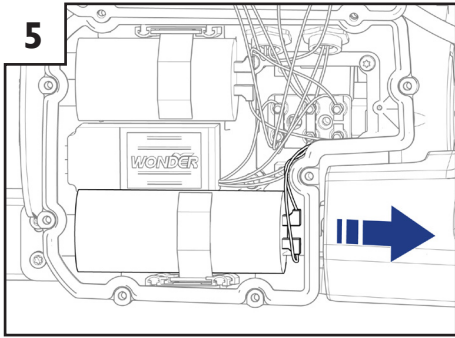
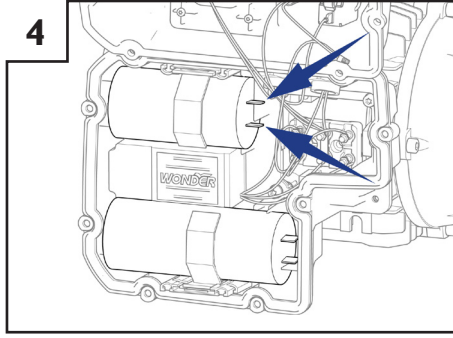
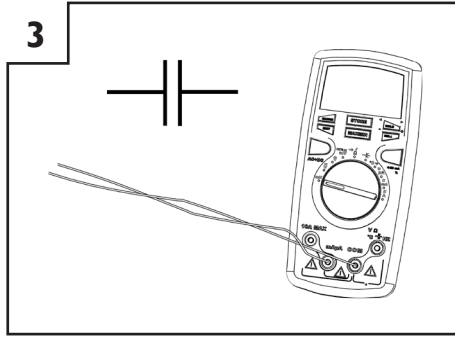
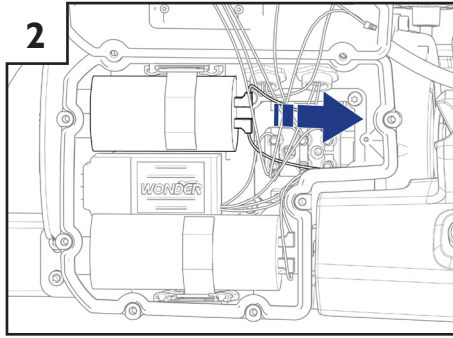
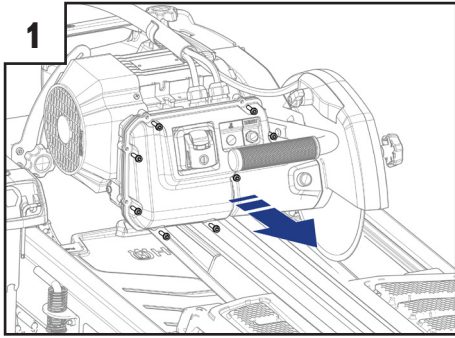

## Capacitor Check

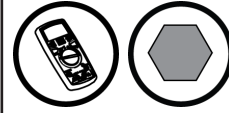

1. Open the front cover on the connection box by removing the 8 screws.
2. Disconnect the wires from the starting capacitor (the smaller one).
3. Set the multimeter to measure capacitance ( $\mu\text{F}$ ). (See symbol in Picture)
4. Connect the two multimeter probes to the connection points on the capacitor.
5. Repeat this steps with the running capacitor. (the larger one)

Replace the capacitor if any of the values measured in step 4 is outside the values stated in, Capacitance Values for Capacitors in chapter: [9. Specification \(p. 35\)](#)

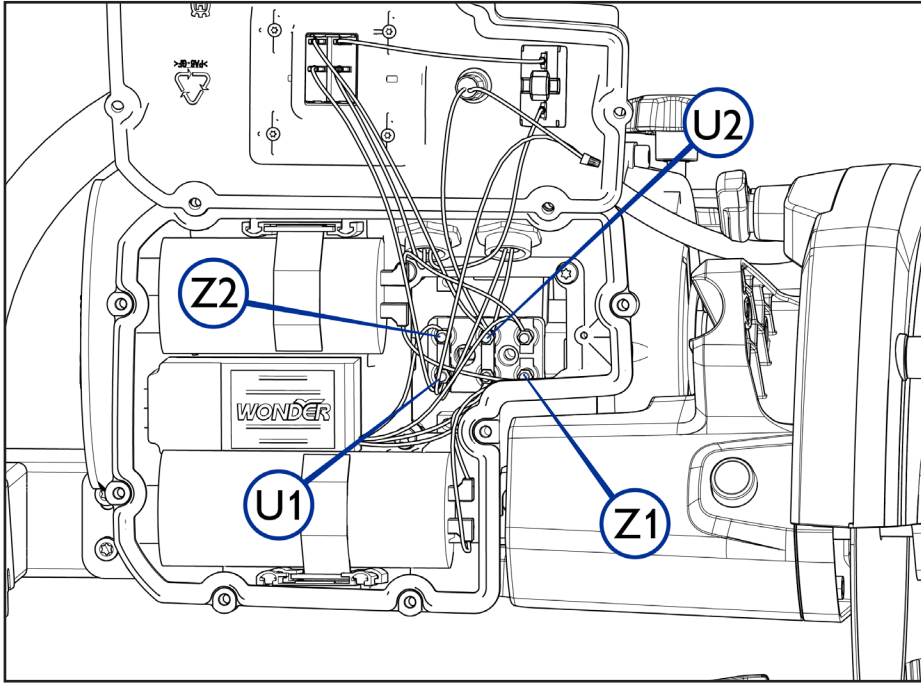

### Motor winding inductance measuring, single voltage

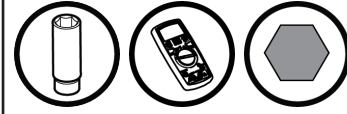

1. Open the front cover on the connection box by unscrew the 8 screws.

Identify the four wires that goes from the connection box to the motor windings inside the motor. The yellow coloured wires on Z1- and Z2- position. The black coloured wires on U1- and U2- position.

(Single Voltage (p. 36))

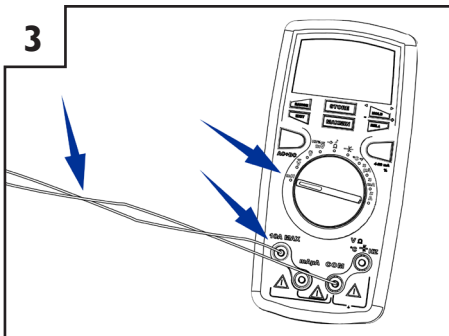
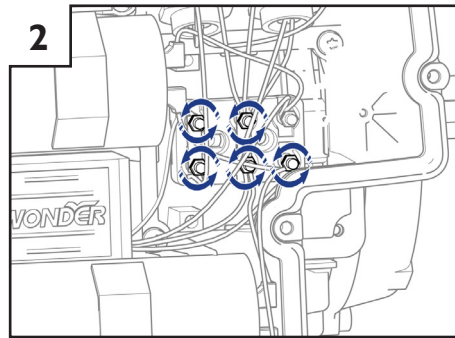
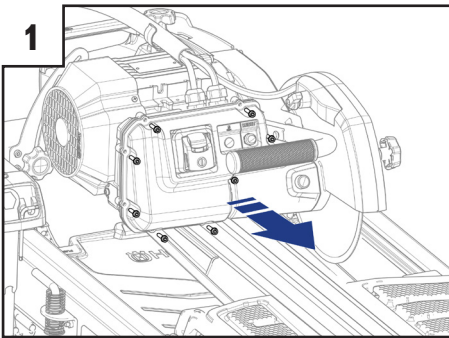

2. Remove the 5 nuts from the connection block to remove the 4 wires that are connected to the motor windings inside the motor.
3. Twist the multimeter probe wires. Set the multimeter to measure "mH" and connect the probe wires to the "H" and "COM" channels.

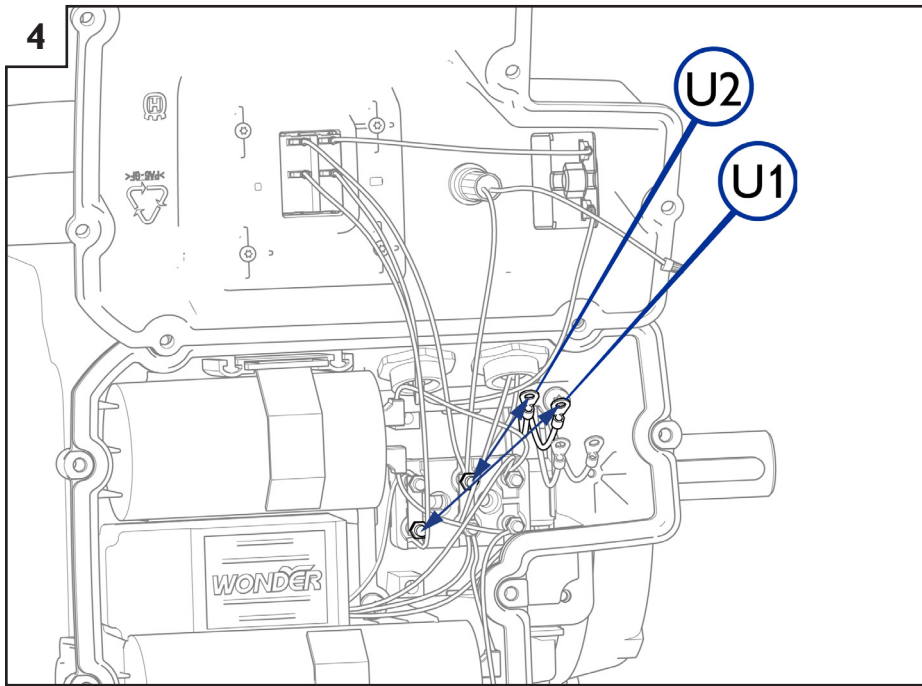

4. Remove the 2 black coloured wires from the connection block at U1 and U2. Make sure the wires are connected to the motor windings. Connect the two multimeter probe wires to the two black coloured wires. Wait a few seconds and then read the value in the multimeter.

5. Remove the 2 Yellow coloured wires from the connection block at Z1 and Z2. Make sure the wires are connected to the motor windings. Connect the two multimeter probe wires to the two black coloured wires. Wait a few seconds and then read the value in the multimeter.

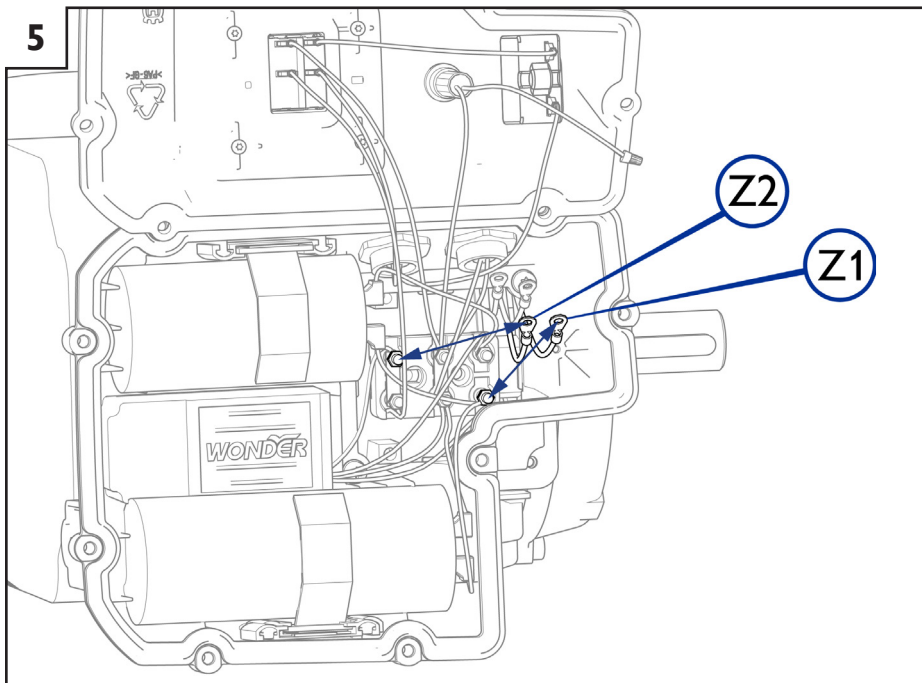

Replace the motor if any of the values measured in step 4 and 5 is outside the values stated in, [Motor measuring values - Single voltage \(p. 35\)](#)

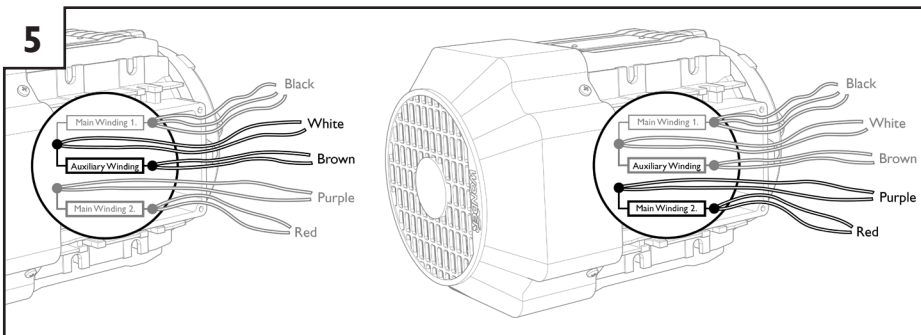
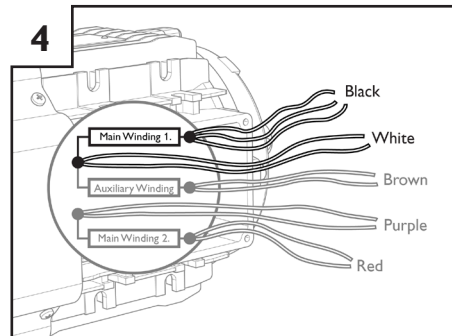
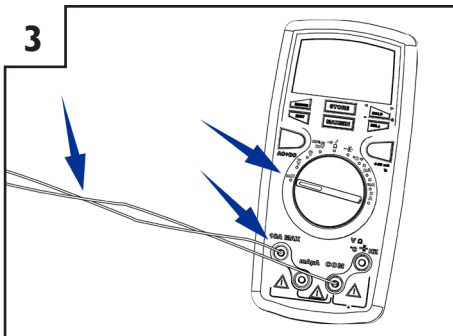
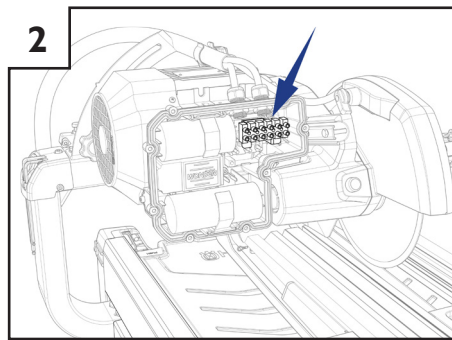
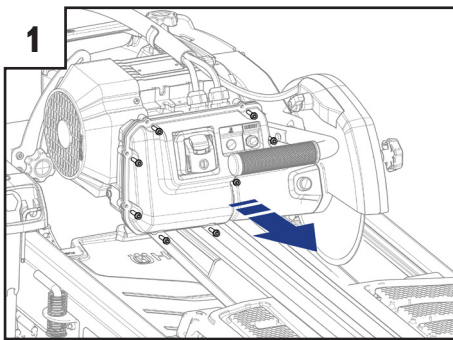
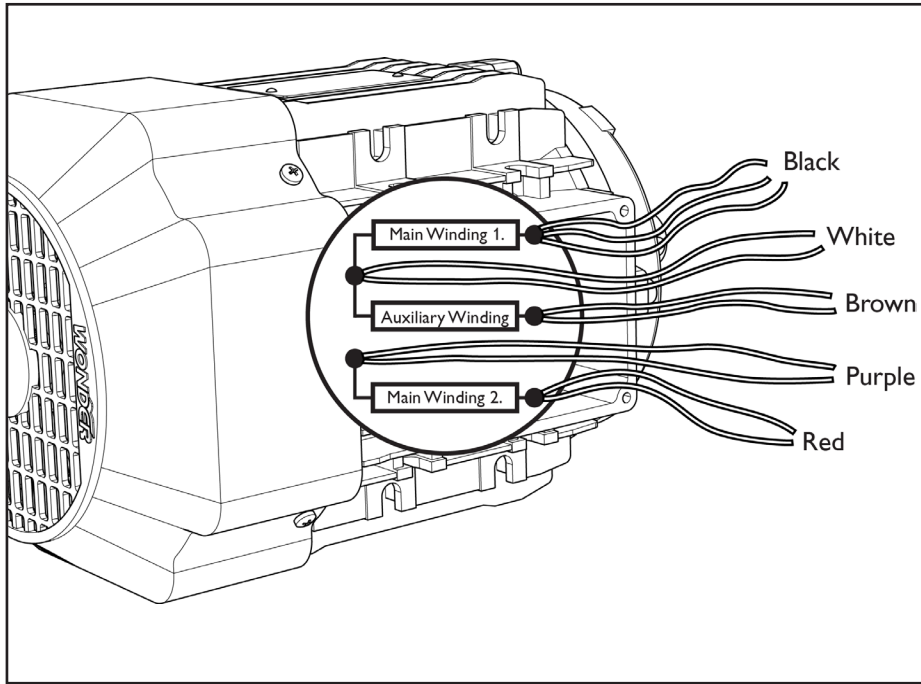

### Motor winding inductance measuring, dual voltage

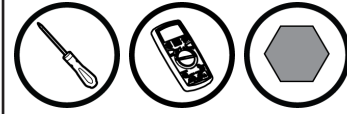

1. Open the front cover on the connection box by unscrew the 8 screws.
2. Identify the 11 wires that goes to the motor windings inside the motor.  
([Dual Voltage \(p. 37\)](#) and [Dual Voltage Motor Windings \(p. 38\)](#)) Mark the wires with their position and loosen them in the other end.
3. Twist the multimeter probe wires. Set the multimeter to measure "mH" and connect the probes to the "H" and "COM" channels.
4. Connect the two multimeter probe wires to one of the 3 black coloured wires and the other probe to one of the 2 white coloured wires to measure the main winding 1. Wait a few seconds and then read the value on the multimeter. Measure the other combinations between the black and white wires too to ensure the wire connections inside the motor are intact.
5. Repeat step 4 on the Auxiliary winding (between white and brown wires) and the main winding 2 (between purple and red wires).
6. Replace the motor if any of the values measured in step 4 and 5 are outside the values stated in, [Motor measuring values - Dual voltage \(p. 35\)](#)

**9. SPECIFICATION**

**Motor measuring values - Single voltage**

<b>Motor p/n</b>		586 60 54-01	586 60 54-02
<b>Model</b>		MS360	TS70,TS90,MS360
<b>Voltage [V]</b>		230	115
<b>Frequency [Hz]</b>		60	60
<b>Power [kW]</b>		2.2	1.1
<b>Phases</b>		1	1
<b>Run Capacitor</b>	<b>µF</b>	40	70
	<b>V</b>	450	300
<b>Start Capacitor</b>	<b>µF</b>	200	300
	<b>V</b>	250	150
<b>Induction value cable pair 1</b>	<b>Inductance Value [mH]</b>	9.4 mH ± 0.5	6.0 mH ± 0.5
	<b>Wire colour</b>	Yellow-yellow	Yellow-yellow
<b>Induction value cable pair 2</b>	<b>Inductance Value [mH]</b>	6.3 mH ± 0.5	2.5 mH ± 0.5
	<b>Wire colour</b>	Black-black	Black-black

**Motor measuring values - Dual voltage**

<b>Motor p/n</b>		586 60 55-01	586 60 55-02
<b>Model</b>		TS90,MS360	MS360
<b>Voltage [V]</b>		115-230	115-230
<b>Frequency [Hz]</b>		60	60
<b>Power [kW]</b>		1.1	1.5
<b>Phases</b>		1	1
<b>Run Capacitor</b>	<b>µF</b>	70	75
	<b>V</b>	300	300
<b>Start Capacitor</b>	<b>µF</b>	300	400
	<b>V</b>	150	150
<b>Induction value Main winding 1</b>	<b>Inductance Value [mH]</b>	4.8 mH ± 0.5	3.8 mH ± 0.4
	<b>Amount-/Wire-colour</b>	3X Black-2X White	3X Black-2X White
<b>Induction value Auxiliary winding</b>	<b>Inductance Value [mH]</b>	6.2 mH ± 0.5	3.9 mH ± 0.4
	<b>Amount-/Wire-colour</b>	2X White-2X Brown	2X White-2X Brown
<b>Induction value Main winding 2</b>	<b>Inductance Value [mH]</b>	4.7 mH ± 0.5	4.2 mH ± 0.5
	<b>Amount-/Wire-colour</b>	2X Purple-2X Red	2X Purple-2X Red

10. WIRING DIAGRAM

Single Voltage

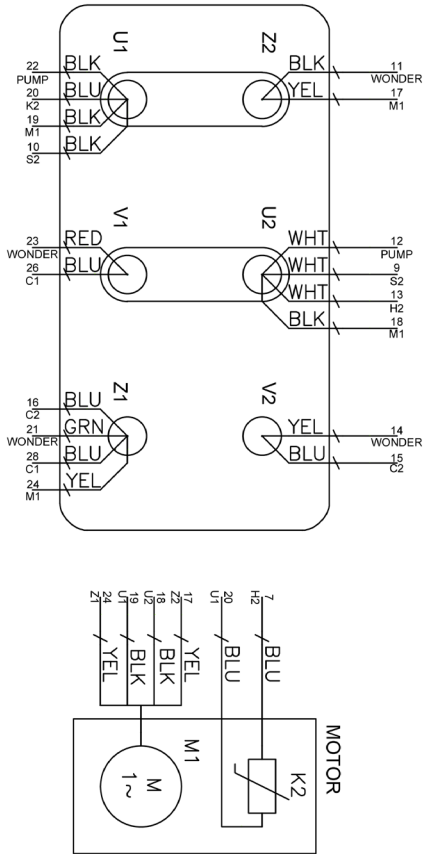
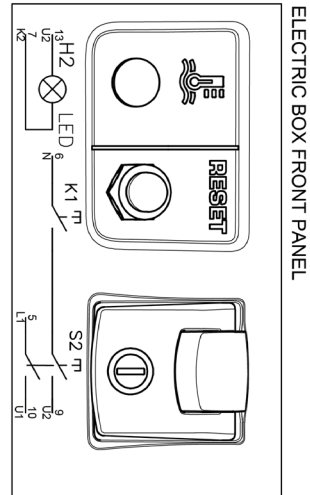
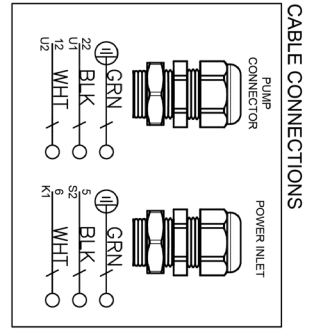
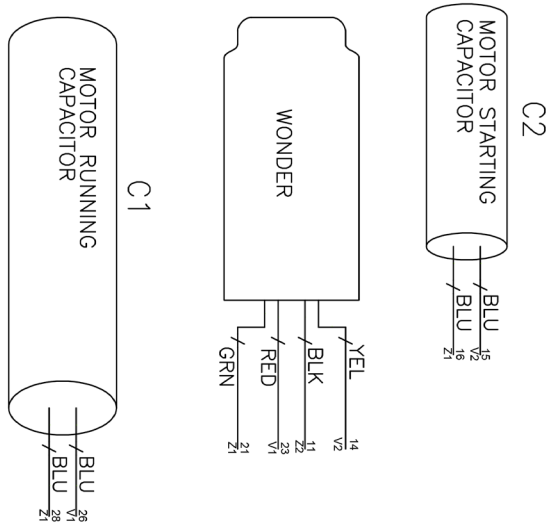

Note! The number printed above each wire is unique for each wire.  
 Printed underneath the wire is the name on the component which the wire connects to.

## Dual Voltage

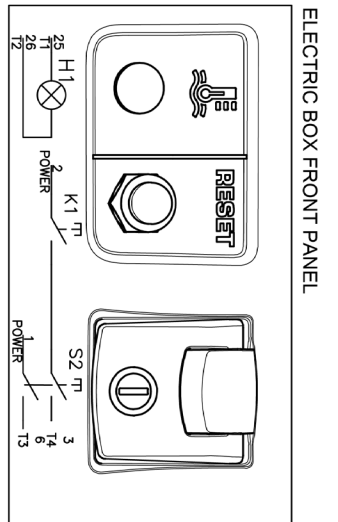
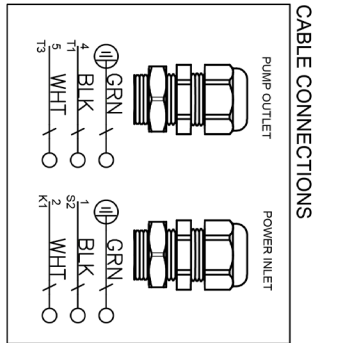

C2

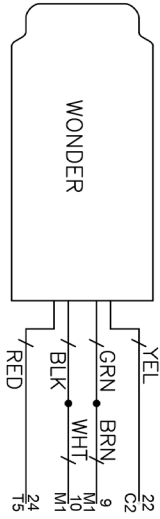
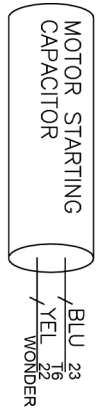

C1



DUAL VOLTAGE SWITCH

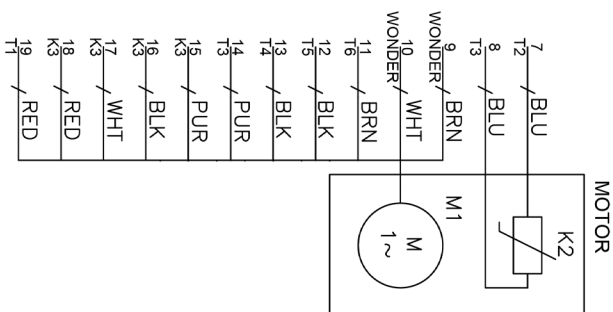
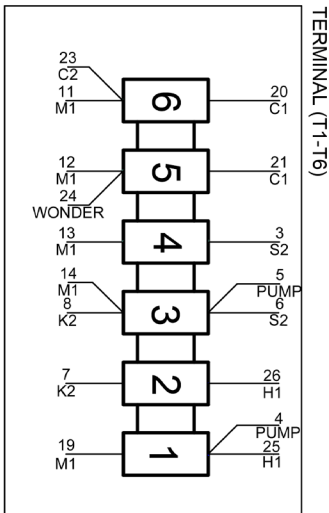
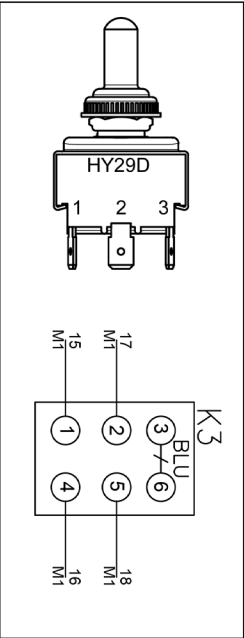

Note! The number printed above each wire is unique for each wire.  
Printed underneath the wire is the name on the component which the wire connects to.

Dual Voltage Motor Windings

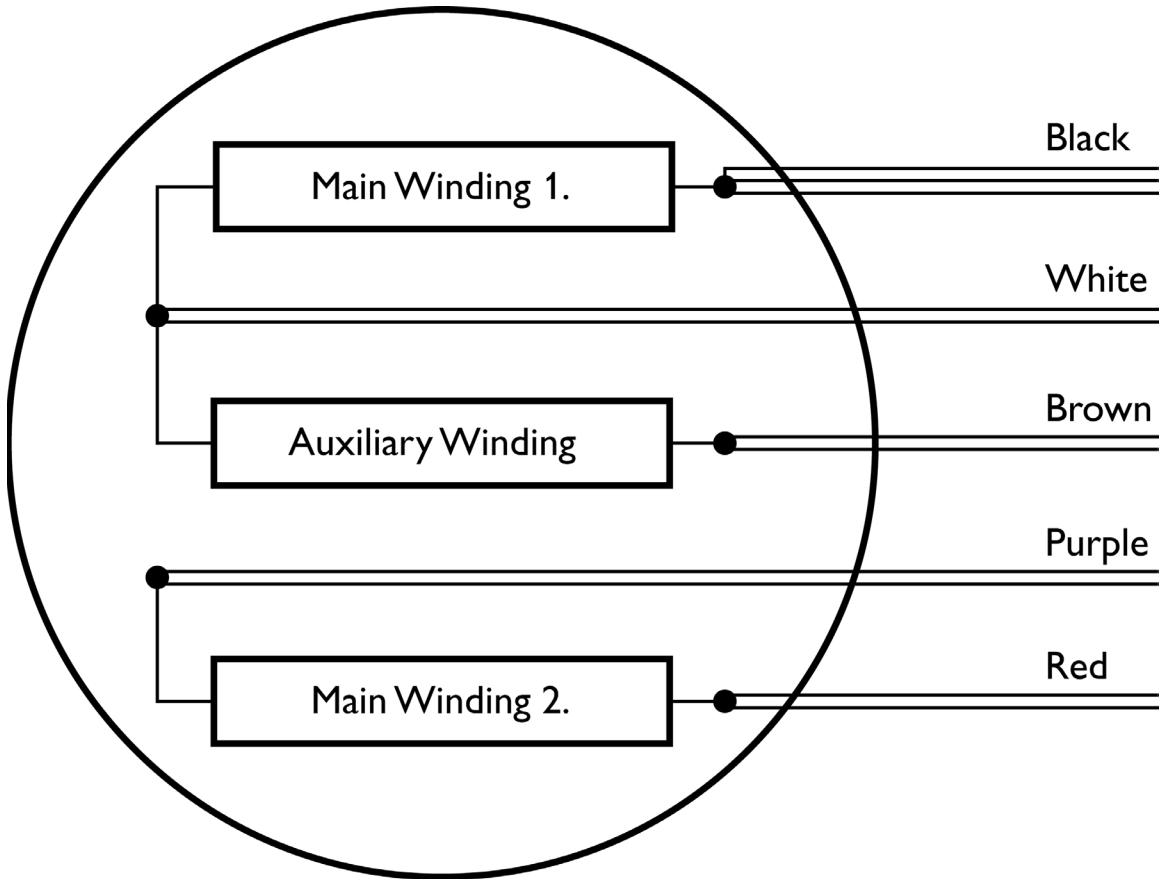



[www.husqvarnacp.com](http://www.husqvarnacp.com)

587 72 94-29

English